

HD74LS670 ● 4-by-4 Register File (with three-state outputs)

The HD74LS670, 16-bit register files incorporate the equivalent of 98 gates. The register file is organized as 4 words of 4 bits each and separate on-chip decoding is provided for addressing the the four word locations to either write-in or retrieve data.

This permits simultaneous writing into one location and reading from another word location. Four data inputs are available which are used to supply the 4-bit word to be stored. Location of the word is determined by the write-address inputs A and B in conjunction with a write-enable signal. Data applied at the inputs should be in its true form. That is, if a high-level signal is desired from the output, a high-level is applied at the data input for that particular bit location. The latch inputs are arranged so that new data will be accepted only if both internal address gate inputs are high. When this condition exists, data at the D input is transferred to the latch output. When the write-enable input, G_W , is high, the data inputs are inhibited and their levels can cause no change in the information stored in the internal latches. When the read-enable input, G_R , is high, the data outputs are inhibited and go into the high-impedance state. The individual address lines permit direct acquisition of data stored in any four of the latches. Four individual decoding gates are used to complete the address for reading a word.

When the read address is made in conjunction with the read-enable signal, the word appears at the four outputs.

■ BLOCK DIAGRAM

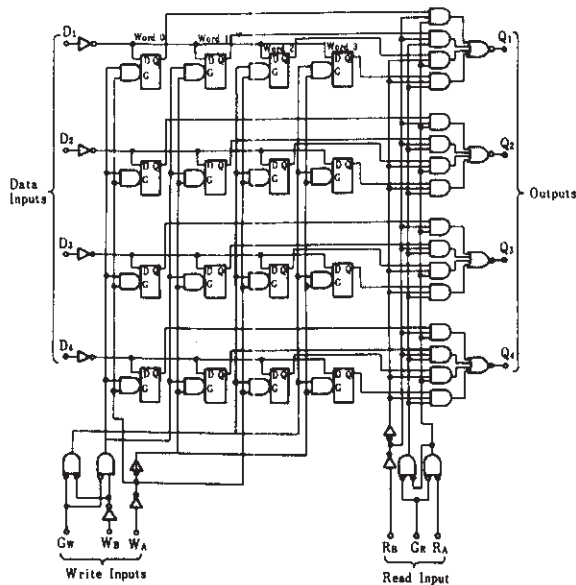

■ PIN ARRANGEMENT

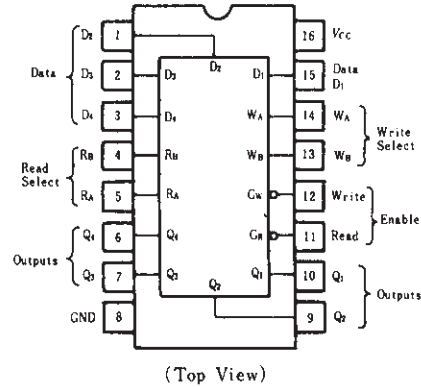

■ FUNCTION TABLE

Write Inputs			Word			
W_B	W_A	G_W	0	1	2	3
L	L	L	$Q = D$	Q_0	Q_0	Q_0
L	H	L	Q_0	$Q = D$	Q_0	Q_0
H	L	L	Q_0	Q_0	$Q = D$	Q_0
H	H	L	Q_0	Q_0	Q_0	$Q = D$
X	X	H	Q_0	Q_0	Q_0	Q_0

Read Inputs			Outputs			
R_B	R_A	G_R	Q_1	Q_2	Q_3	Q_4
L	L	L	$W_0 B_1$	$W_0 B_2$	$W_0 B_3$	$W_0 B_4$
L	H	L	$W_1 B_1$	$W_1 B_2$	$W_1 B_3$	$W_1 B_4$
H	L	L	$W_2 B_1$	$W_2 B_2$	$W_2 B_3$	$W_2 B_4$
H	H	L	$W_3 B_1$	$W_3 B_2$	$W_3 B_3$	$W_3 B_4$
X	X	H	Z	Z	Z	Z

Notes: H = high level, L = low level, X = irrelevant, Z = high impedance (off)
 $(Q=D)$ = The four selected internal flip-flop outputs will assume the states applied to the four external data inputs.
 Q_0 = The level of Q before the indicated input conditions were established.
 $W_0 B_1$ = The first bit of word 0, etc.

HD74LS670

RECOMMENDED OPERATING CONDITIONS

Item	Symbol	min	typ	max	Unit
Supply voltage	V_{CC}	4.75	5.00	5.25	V
Output current	I_{OH}	—	—	-2.6	mA
	I_{OL}	—	—	8	mA
Pulse width	Read enable	t_w	25	—	ns
	Write enable	t_w	60	—	ns
Setup time	Data	t_s	10	—	ns
	Write enable	t_s	15	—	ns
Hold time	Data	t_h	15	—	ns
	Write enable	t_h	5	—	ns
Latch time	t_{latch}	60	—	—	ns

ELECTRICAL CHARACTERISTICS ($T_a = -20 \sim +75^\circ\text{C}$)

Item	Symbol	Test Conditions	min	typ*	max	Unit	
Input voltage	V_{IH}		2.0	—	—	V	
	V_{IL}		—	—	0.8	V	
Output voltage	V_{OH}	$V_{CC}=4.75\text{V}, V_{IH}=2\text{V}, V_{IL}=0.8\text{V}, I_{OH}=-2.6\text{mA}$	2.4	—	—	V	
	V_{OL}	$V_{CC}=4.75\text{V}, V_{IH}=2\text{V}, V_{IL}=0.8\text{V}$	—	—	0.4	V	
Off-state output current	I_{OZH}	$V_{CC}=5.25\text{V}, V_{IH}=2\text{V}$	$V_O=2.7\text{V}$	—	—	20	μA
	I_{OZL}		$V_O=0.4\text{V}$	—	—	-20	μA
Input current	I_{IH}	$V_{CC}=5.25\text{V}, V_I=2.7\text{V}$	Any D, R or W	—	—	20	μA
			G_w	—	—	40	μA
			G_R	—	—	60	μA
	I_{IL}	$V_{CC}=5.25\text{V}, V_I=0.4\text{V}$	Any D, R or W	—	—	-0.4	mA
			G_w	—	—	-0.8	mA
			G_R	—	—	-1.2	mA
I_I	$V_{CC}=5.25\text{V}, V_I=7\text{V}$	Any D, R or W	—	—	0.1	mA	
		G_w	—	—	0.2	mA	
		G_R	—	—	0.3	mA	
Short-circuit output current	I_{OS}	$V_{CC}=5.25\text{V}$	-30	—	-130	mA	
Supply current	I_{CC}^{**}	$V_{CC}=5.25\text{V}$	—	30	50	mA	
Input clamp voltage	V_{IK}	$V_{CC}=4.75\text{V}, I_{IN}=-18\text{mA}$	—	—	-1.5	V	

* $V_{CC}=5\text{V}, T_a=25^\circ\text{C}$

** : Maximum I_{CC} is guaranteed for the following worst case conditions: 4.5V is applied to all data inputs and both enable inputs, all address inputs are grounded and all outputs are open.

SWITCHING CHARACTERISTICS ($V_{CC}=5\text{V}, T_a=25^\circ\text{C}$)

Item	Symbol	Inputs	Outputs	Test Conditions	min	typ	max	Unit	
Propagation delay time	t_{PLH}	Read select	$Q_1 \sim Q_4$	$C_L=15\text{pF}, R_L=2\text{k}\Omega$	—	23	40	ns	
	t_{PHL}				—	25	45		
	t_{PLH}	Write enable	$Q_1 \sim Q_4$		—	26	45		
	t_{PHL}				—	28	50		
	Output enable time	t_{PLH}	Data		$Q_1 \sim Q_4$	—	25		45
		t_{PHL}				—	23		40
Output disable time	t_{ZH}	Read enable	$Q_1 \sim Q_4$	$C_L=5\text{pF}, R_L=2\text{k}\Omega$	—	15	35		
	t_{ZL}				—	22	40		
Output disable time	t_{HZ}			—	30	50			
	t_{LZ}			—	16	35			

HD74LS670

TESTING METHOD

Test Circuit

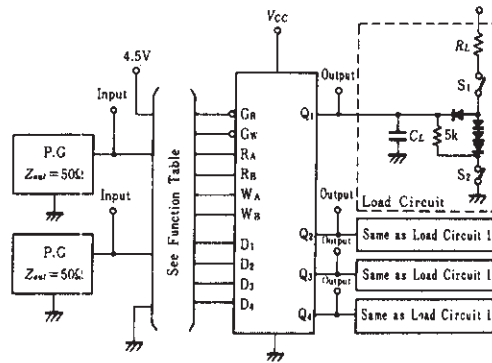

- Notes:
1. C_L includes probe and jig capacitance.
 2. All diodes are 1S2074 \oplus .

Waveform-1

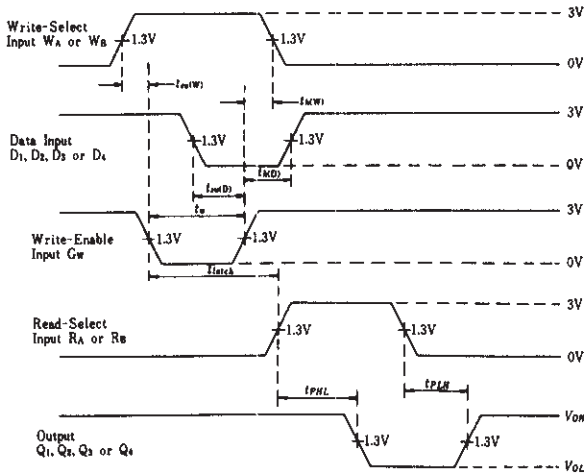

- Notes:
1. High-level input pulses at the select and data inputs are illustrated; however, times associated with low-level pulses are measured from the same reference points.
 2. When measuring delay times from a read-select inputs, the read-enable input is low.
 3. Input pulse; $t_{TLH} \leq 15\text{ns}$, $t_{THL} \leq 6\text{ns}$, $PRR = 1\text{MHz}$, duty cycle 50%

Waveform-2

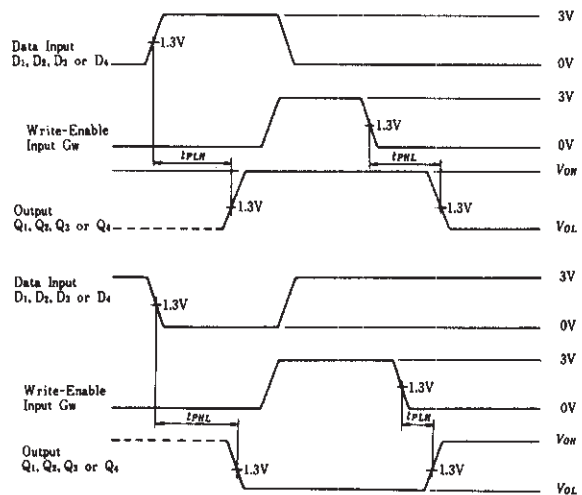

- Note:
- Each select address is tested. Prior to the start of each of the above test both write and read address inputs are stabilized with $W_A = R_A$ and $W_B = R_B$. During the test G_R is low.

Waveform-3

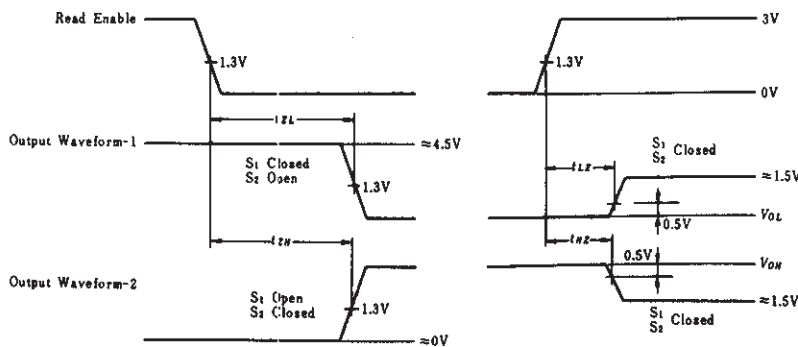

Waveform A is for an output with internal conditions such that the output is low except when disabled by the read-enable input. Waveform B is for an output with internal conditions such that the output is high except when disabled by the read-enable input.

Unit: mm

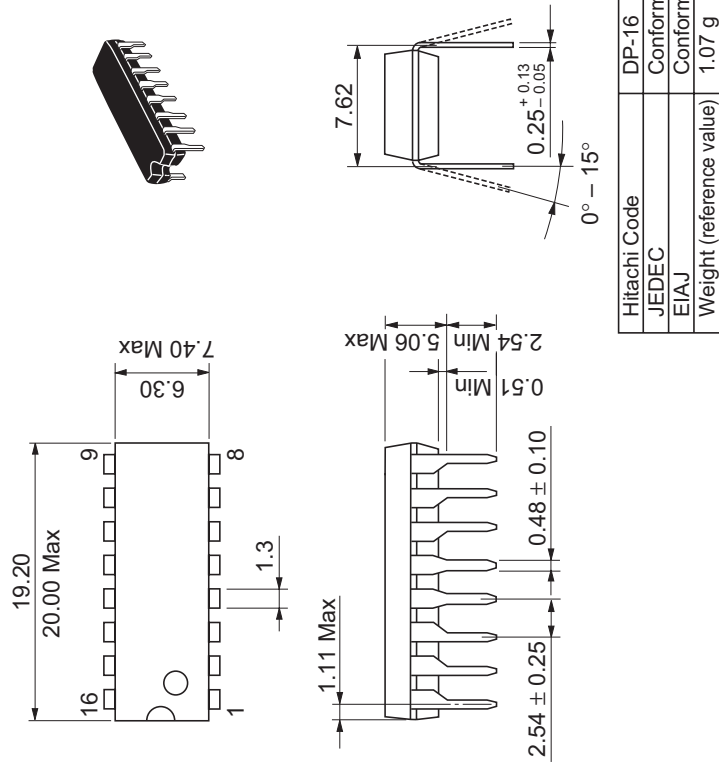

Unit: mm

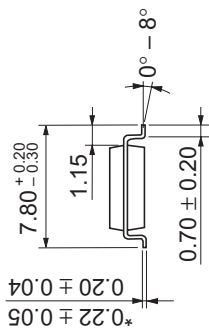
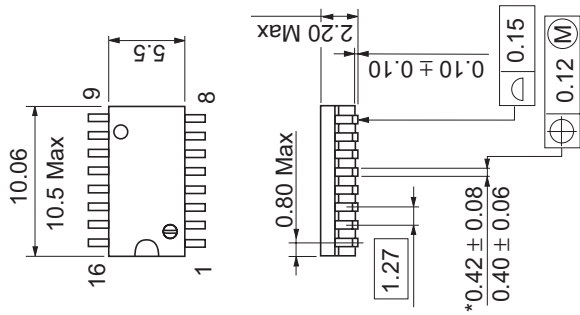

*Dimension including the plating thickness

 Base material dimension

Hitachi Code	FP-16DA
JEDEC	—
EIAJ	Conforms
Weight (reference value)	0.24 g

Unit: mm

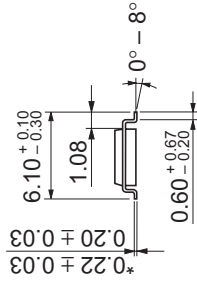
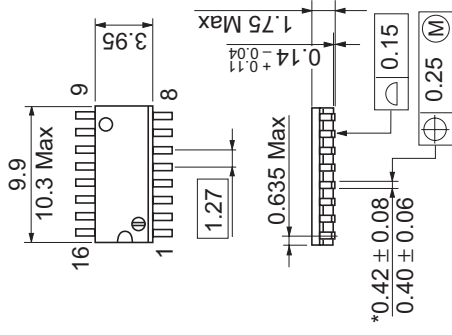

*Dimension including the plating thickness

 Base material dimension

Hitachi Code	FP-16DN
JEDEC	Conforms
EIAJ	Conforms
Weight (reference value)	0.15 g

Cautions

1. Hitachi neither warrants nor grants licenses of any rights of Hitachi's or any third party's patent, copyright, trademark, or other intellectual property rights for information contained in this document. Hitachi bears no responsibility for problems that may arise with third party's rights, including intellectual property rights, in connection with use of the information contained in this document.
2. Products and product specifications may be subject to change without notice. Confirm that you have received the latest product standards or specifications before final design, purchase or use.
3. Hitachi makes every attempt to ensure that its products are of high quality and reliability. However, contact Hitachi's sales office before using the product in an application that demands especially high quality and reliability or where its failure or malfunction may directly threaten human life or cause risk of bodily injury, such as aerospace, aeronautics, nuclear power, combustion control, transportation, traffic, safety equipment or medical equipment for life support.
4. Design your application so that the product is used within the ranges guaranteed by Hitachi particularly for maximum rating, operating supply voltage range, heat radiation characteristics, installation conditions and other characteristics. Hitachi bears no responsibility for failure or damage when used beyond the guaranteed ranges. Even within the guaranteed ranges, consider normally foreseeable failure rates or failure modes in semiconductor devices and employ systemic measures such as fail-safes, so that the equipment incorporating Hitachi product does not cause bodily injury, fire or other consequential damage due to operation of the Hitachi product.
5. This product is not designed to be radiation resistant.
6. No one is permitted to reproduce or duplicate, in any form, the whole or part of this document without written approval from Hitachi.
7. Contact Hitachi's sales office for any questions regarding this document or Hitachi semiconductor products.

HITACHI

Hitachi, Ltd.

Semiconductor & Integrated Circuits.
Nippon Bldg., 2-6-2, Ohte-machi, Chiyoda-ku, Tokyo 100-0004, Japan
Tel: Tokyo (03) 3270-2111 Fax: (03) 3270-5109

URL NorthAmerica : <http://semiconductor.hitachi.com/>
 Europe : <http://www.hitachi-eu.com/hel/ecg>
 Asia (Singapore) : <http://www.has.hitachi.com.sg/grp3/sicd/index.htm>
 Asia (Taiwan) : http://www.hitachi.com.tw/E/Product/SICD_Frame.htm
 Asia (HongKong) : <http://www.hitachi.com.hk/eng/bo/grp3/index.htm>
 Japan : <http://www.hitachi.co.jp/Sicd/indx.htm>

For further information write to:

Hitachi Semiconductor
(America) Inc.
179 East Tasman Drive,
San Jose, CA 95134
Tel: <1> (408) 433-1990
Fax: <1> (408) 433-0223

Hitachi Europe GmbH
Electronic components Group
Dornacher StraÙe 3
D-85622 Feldkirchen, Munich
Germany
Tel: <49> (89) 9 9180-0
Fax: <49> (89) 9 29 30 00

Hitachi Europe Ltd.
Electronic Components Group.
Whitebrook Park
Lower Cookham Road
Maidenhead
Berkshire SL6 8YA, United Kingdom
Tel: <44> (1628) 585000
Fax: <44> (1628) 778322

Hitachi Asia Pte. Ltd.
16 Collyer Quay #20-00
Hitachi Tower
Singapore 049318
Tel: 535-2100
Fax: 535-1533

Hitachi Asia Ltd.
Taipei Branch Office
3F, Hung Kuo Building, No.167,
Tun-Hwa North Road, Taipei (105)
Tel: <886> (2) 2718-3666
Fax: <886> (2) 2718-8180

Hitachi Asia (Hong Kong) Ltd.
Group III (Electronic Components)
7/F., North Tower, World Finance Centre,
Harbour City, Canton Road, Tsim Sha Tsui,
Kowloon, Hong Kong
Tel: <852> (2) 735 9218
Fax: <852> (2) 730 0281
Telex: 40815 HITEC HX

Copyright ' Hitachi, Ltd., 1999. All rights reserved. Printed in Japan.

HITACHI