

LCD Module User Manual

Customer : _____
Ordering Part No. : TG12864D0-04WA0
DRAWING NO. : m-TG12864D0-04WA0_A00

Approved By Customer:

Date:

Approved By	Checked By	Prepared By

Vatronix Holdings Limited

ADD:5F,No.10 Blg,WenGuang Industrial Zone,XiLi,Nanshan District,Shenzhen,China

TEL:0086-755-83234801 33207538 FAX:0086-755-33207539

E-mail:sales@vatronix.com [Http://www.vatronix.com](http://www.vatronix.com)

Contents

1. Precautions in Use of LCD Module-----	P3
2. General Specification-----	P3
3. Absolute Maximum Ratings-----	P3
4. Electrical Characteristics-----	P4
5. Backlight Information-----	P4
6. Optical Characteristics-----	P5
7. Interface Description-----	P6
8. Contour Drawing & Block Diagram-----	P7
9. Application circuit-----	P8
10. Timing Characteristics-----	P9
11. Display Control Instruction-----	P10
11.1 Instruction table-----	P10
11.2 Instruction description -----	P10
12. Reset and Initializing flow chart -----	P12
13. Display Data RAM map -----	P13
14. Revision records-----	P14

1. Precautions in Use of LCD Module

- (1) Avoid applying excessive shocks to the module or making any alterations or modifications to it.
- (2) Don't make extra holes on the printed circuit board, modify its shape or change the components of LCD Module.
- (3) Don't disassemble the LCD Module.
- (4) Don't operate it above the absolute maximum rating.
- (5) Don't drop, bend or twist LCD Module.
- (6) Soldering: only to the I/O terminals.
- (7) Storage: please storage in anti-static electricity container and clean environment.

2. General Specification

Item	Standard Value	Unit
Number of dots	128X64	Dots
Outline dimension	75.0(W)X52.7(H)X 9.0 MAX.(T)	mm
View area	60.0(W)X 32.5(H)	mm
Active area	55.0(W)X 27.48(H)	mm
Dot size	0.39(W)X 0.39(H)	mm
Dot pitch	0.43(W)X 0.43(H)	mm
LCD type	FSTN,Positive,Transflective	
View direction	6 o'clock	
Backlight	LED,White	
Interface	Parallel	

3. Absolute Maximum Ratings

ITEM	SYMBOL	MIN.	TYP.	MAX.	UNIT
Operating Temperature	T _{OP}	-20	-	+70	
Storage Temperature	T _{ST}	-30	-	+80	
Input Voltage	V _I	0	-	V _{DD}	V
Supply Voltage For Logic	V _{DD}	0	-	5.5	V
Supply Voltage For LCD	V _{DD} -V _{EE}	0	-	5	V

4. Electrical Characteristics

ITEM	SYMBOL	CONDITION	MIN.	TYP.	MAX.	UNIT
Logic Voltage	$V_{DD}-V_{SS}$	-	4.7	5.0	5.2	V
Supply Voltage for LCD	$V_{DD}-V_O$	$T_a=25$	---	10.5	---	V
Input High Volt.	V_{IH}	-	2.0	-	V_{DD}	V
Input Low Volt.	V_{IL}	-	-0.3	-	0.8	V
Output High Volt.	V_{OH}	$I_{OH}=-0.2mA$	2.4	-	V_{DD}	V
Output Low Volt.	V_{OL}	$I_{OL}=1.6mA$	0	-	0.4	V
Supply Current	I_{DD} (Include DC/DC)	-	---	6.0	---	mA

5. Backlight Information

Absolute Maximum ratings ($T_a=25$)

Item	Symbol	Conditions	Rating	Unit
Reverse voltage	V_r	-	5.0	V
Reverse Current	I_r	$V_r=5.0V$	80	μA
Absolute maximum forward Current	I_{fm}		120	mA
Peak forward current	I_{fp}	1 msec plus 10% Duty Cycle	240	mA
Power dissipation	P_d		340	mW
Operating Temperature Range	T_{oper}		-30~+70	
Storage Temperature Range	T_{st}		-40~+80	

Electrical/Optical Characteristics ($T_a=25^{\circ}C, I_f=80mA$)

Color	Wavelength λ (nm)	Spectral line half width (nm)	Operating Voltage(V) ($\pm 0.15V$)	Forward Current (mA)
White	---	---	3.2	80

6. Optical Characteristics

ITEM	SYMBOL	CONDITION	MIN	TYP	MAX	UNIT
View Angle	(V)	CR 2	10	-	120	deg.
	(H)	CR 2	-45	-	45	deg.
Contrast Ratio	CR	-	-	5	-	-
Response Time	T rise	-	-	200	300	ms
	T fall	-	-	150	200	ms

View Angles

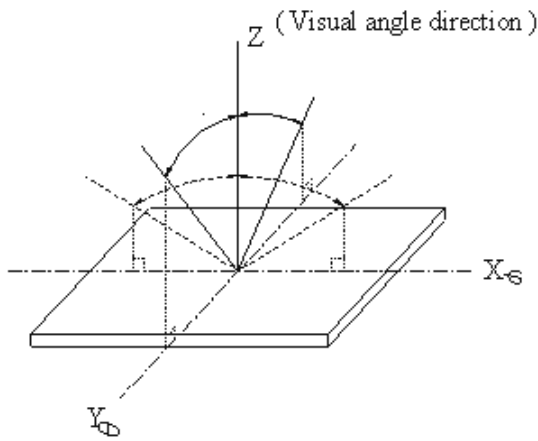

Contrast Ratio

$$CR = \frac{\text{Brightness at selected state (BS)}}{\text{Brightness at non-selected state (Bns)}}$$

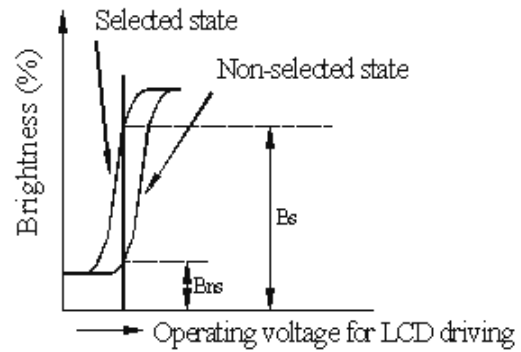

Response time

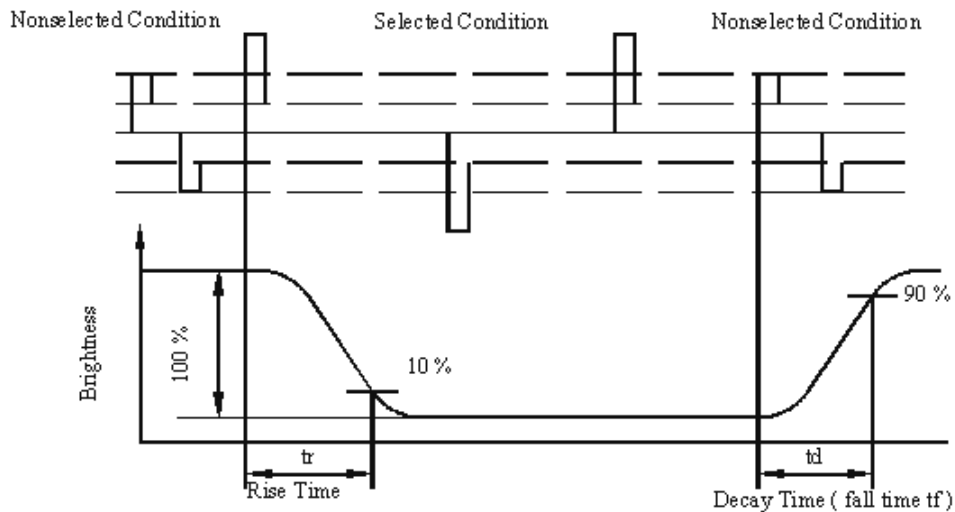

7. Interface Description

Pin No.	Symbol	Level	Description
1	V _{DD}	5.0V	Power supply for Logic
2	V _{SS}	0V	Ground
3	V _O	(Variable)	Driving voltage for LCD
4~11	DB0~DB7	H/L	Data bus. DB7 is used for Busy Flag.
12	/CS1	L	Chip selection for IC1, Active low level
13	/CS2	L	Chip selection for IC2, Active low level
14	RES	H/L	Controller reset signal, Active low level
15	RW	H/L	H:Read L:Write
16	RS	H/L	H:Data L :Instruction
17	E	H/L	Enable signal
18	VEE	-10V	Negative voltage output
19	A(LED+)	+5.0V	Anode of LED Backlight
20	K(LED-)	0V	Cathode of LED Backlight

8. Contour Drawing & Block Diagram

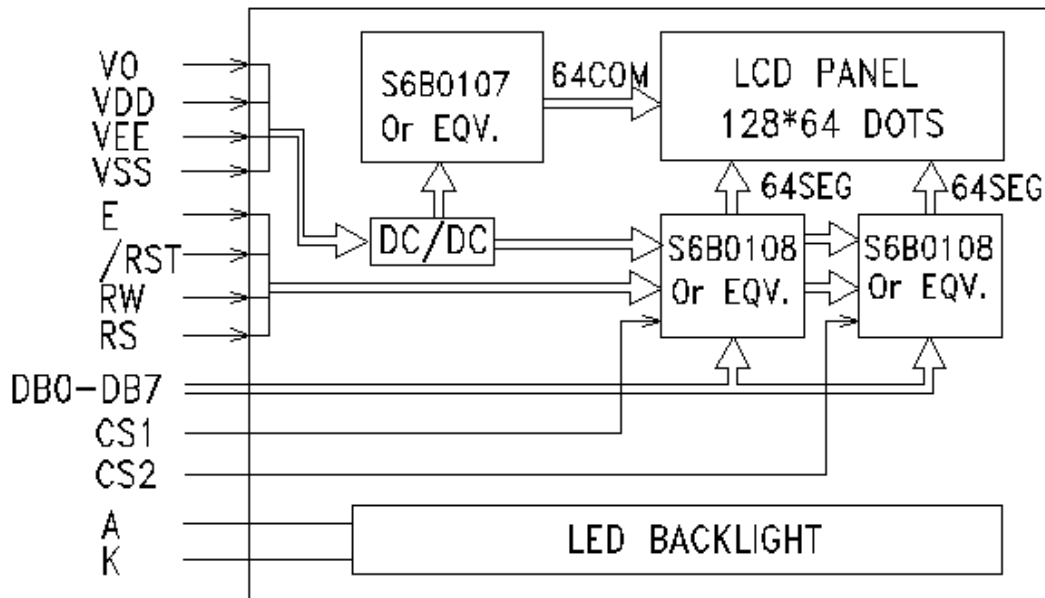
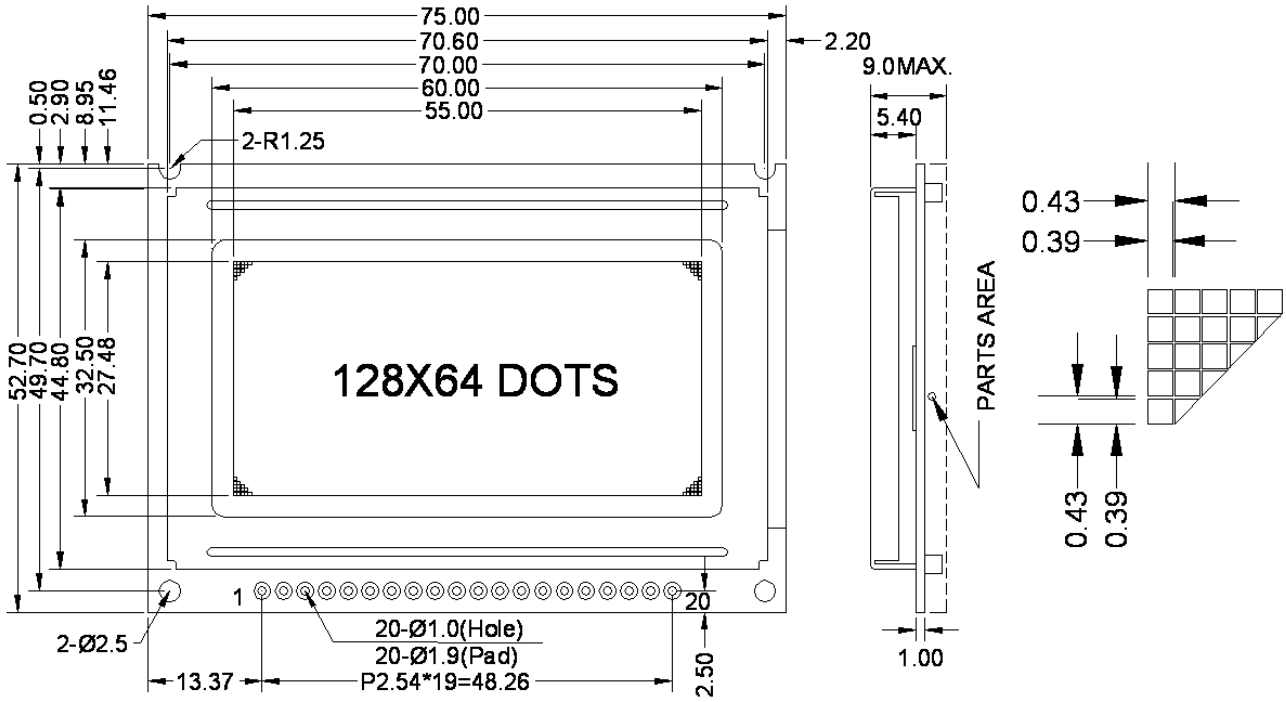

9. Application circuit

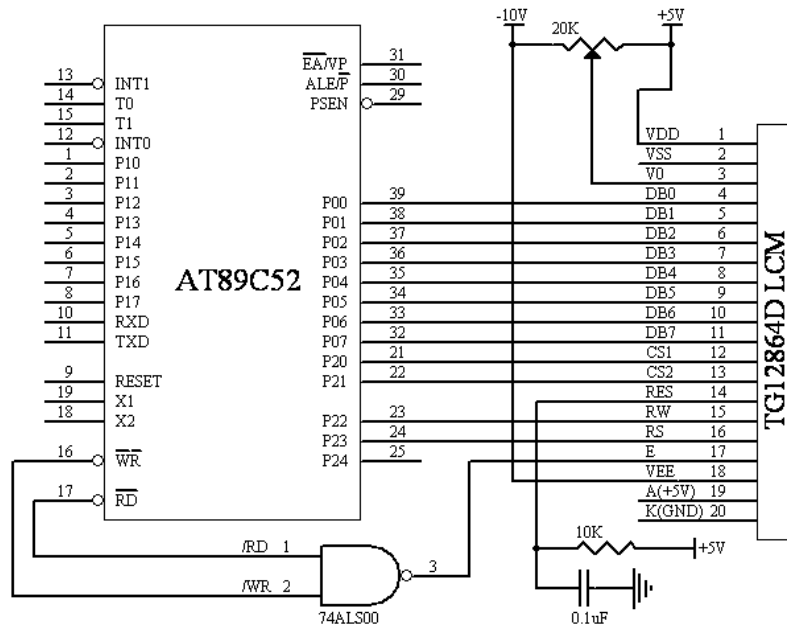

8080-series MPU Circuit

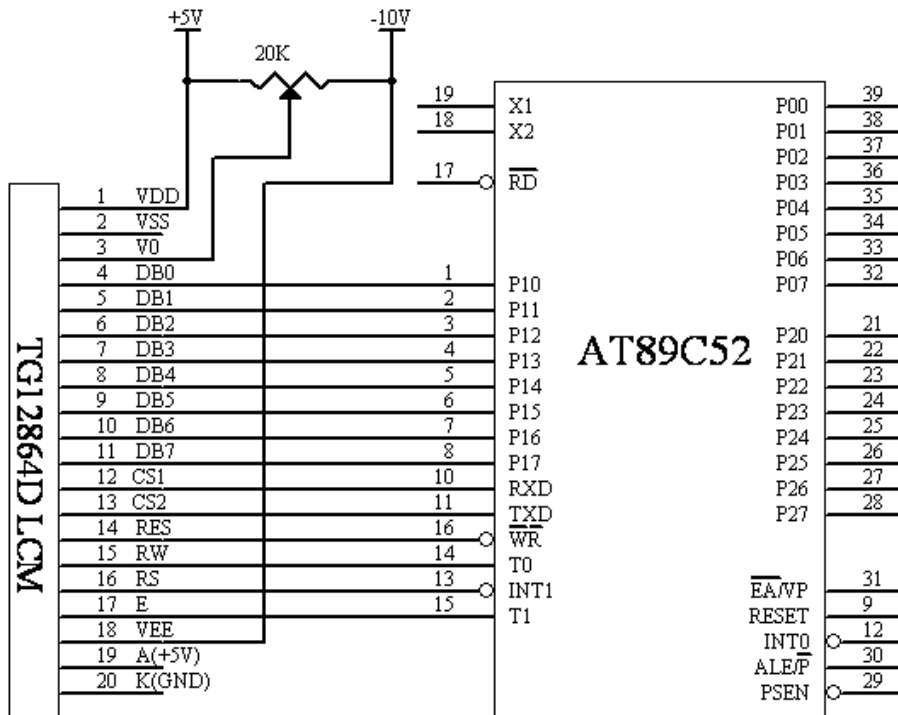

6800-series MPU Circuit

10. Timing Characteristics

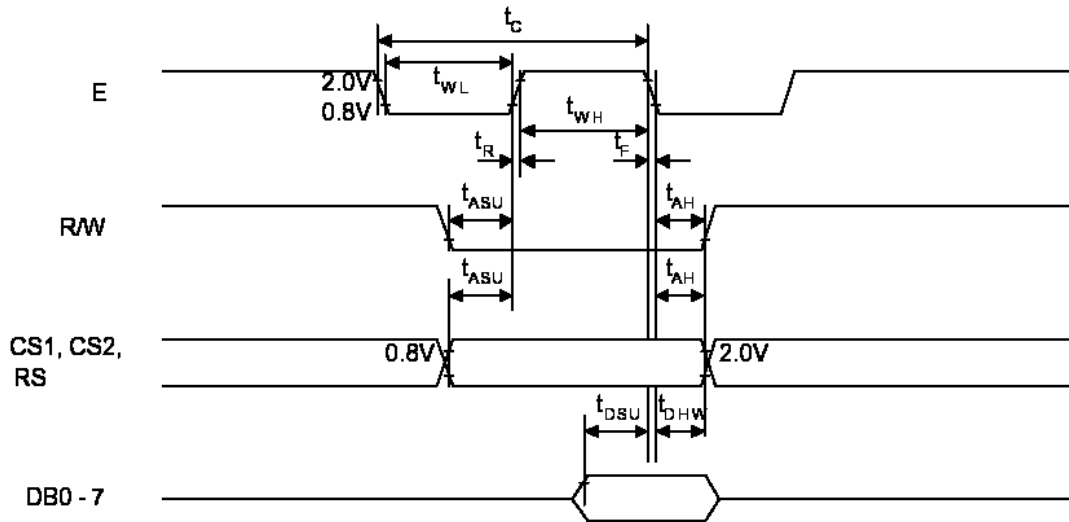

MCU Write data/command to LCM Timing

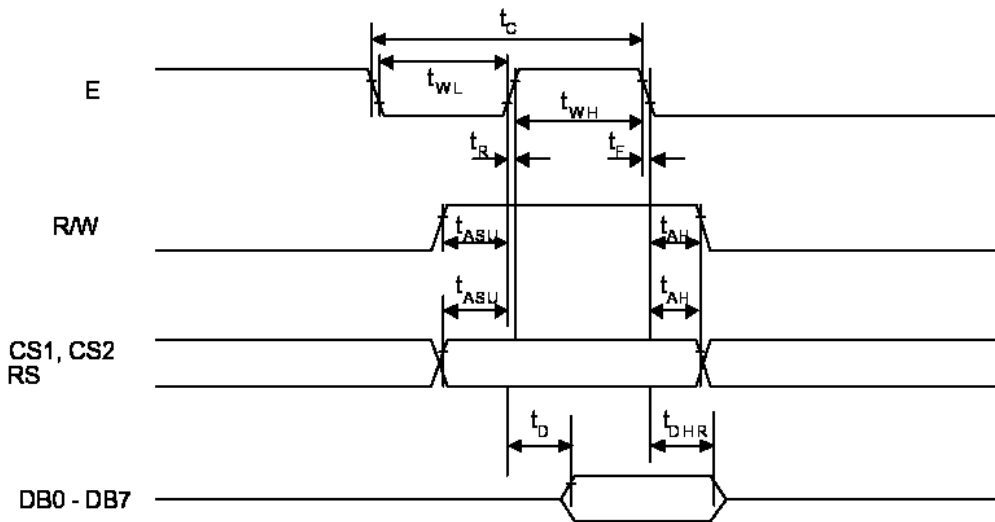

MCU Read data/command from LCM Timing

Characteristic	Symbol	Min.	Type	Max.	Unit
E cycle	t_C	1000	-	-	ns
E high level width	t_{WH}	450	-	-	ns
E low level width	t_{WL}	450	-	-	ns
E rise time	t_R	-	-	25	ns
E fall time	t_F	-	-	25	ns
Address set-up time	t_{ASU}	140	-	-	ns
Address hold time	t_{AH}	10	-	-	ns
Data set-up time	t_{DSU}	200	-	-	ns
Data delay time	t_D	-	-	320	ns
Data hold time (write)	t_{DHW}	10	-	-	ns
Data hold time (read)	t_{DHR}	20	-	-	ns

11. Display Control Instruction

The display control instructions control the internal state of the LCD module. Instruction is received from MPU to LCD module for the display control. The following table shows various instructions.

11.1 Instruction table

Instruction	RS	RW	DB7	DB6	DB5	DB4	DB3	DB2	DB1	DB0	Function	
Display On/off	0	0	0	0	1	1	1	1	1	D	Controls the display ON or OFF. The internal status and the DDRAM data is not affected. D=0: OFF; D=1: ON	
Set Address (Y address)	0	0	0	1	Y address (0~63)						Sets the Y address at the column address counter	
Set Page (X address)	0	0	1	0	1	1	1	Page (0~7)			Sets the X address at the X address register.	
Display Start Line	0	0	1	1	Display start line (0~63)						Indicates the Display Data RAM displayed at the top of the screen.	
Status Read	0	1	Busy	0	ON/OFF	Reset	0	0	0	0	Reads the internal status BUSY 0: Ready 1: In operation ON/OFF 0: Display ON 1: Display OFF RESET 0: Normal 1: Reset	
Write Display Data	1	0	Write data									Writes data (DB[0:7]) into the DDRAM. After writing instruction, Y address is incremented by 1 automatically
Read Display Data	1	1	Read data									Reads data (DB[0:7]) from display data RAM to the data bus.

11.2 Instruction Description

1) Display On/Off

The display data appears when D is 1 and disappears when D is 0.

Though the data is not on the screen with D=0, it remains in the display data RAM.

Therefore, you can make it appear by changing D=0 into D=1.

RS	R/W	DB7	DB6	DB5	DB4	DB3	DB2	DB1	DB0
0	0	0	0	1	1	1	1	1	D

2) Set Address (Y Address)

Y address (AC0~AC5) of the display data RAM is set in the Y address counter.

An address is set by instruction and increased by 1 automatically by read or write operations of display data.

RS	R/W	DB7	DB6	DB5	DB4	DB3	DB2	DB1	DB0
0	0	0	1	AC5	AC4	AC3	AC2	AC1	AC0

3) Set Page (X Address)

X address (AC0~AC2) of the display data RAM is set in the X address register.

Writing or reading to or from MPU is executed in this specified page until the next page is set.

RS	R/W	DB7	DB6	DB5	DB4	DB3	DB2	DB1	DB0
0	0	1	0	1	1	1	AC2	AC1	AC0

4) Display Start Line (Z Address)

Z address (AC0~AC5) of the display data RAM is set in the display start line register and displayed at the top of the screen.

When the display duty cycle is 1/64 or others (1/32~1/64), the data of total line number of LCD screen, from the line specified by display start line instruction, is displayed.

RS	R/W	DB7	DB6	DB5	DB4	DB3	DB2	DB1	DB0
0	0	1	1	AC5	AC4	AC3	AC2	AC1	AC0

5) Status Read

RS	R/W	DB7	DB6	DB5	DB4	DB	DB2	DB	DB0
0	1	BUSY	0	ON/OFF	RESET	0	0	0	0

- **BUSY**

When BUSY is 1, the Chip is executing internal operation and no instructions are accepted.

When BUSY is 0, the Chip is ready to accept any instructions.

- **ON/OFF**

When ON/OFF is 1, the display is off.

When ON/OFF is 0, the display is on.

- **RESET**

When RESET is 1, the system is being initialized. In this condition, no instructions except status read can be accepted.

When RESET is 0, initializing has finished and the system is in the usual operation condition.

6) Write Display Data

Writes data (D0~D7) into the display data RAM. After writing, Y address is increased by 1 automatically.

RS	R/W	DB7	DB6	DB5	DB4	DB3	DB2	DB1	DB0
1	0	D7	D6	D5	D4	D3	D2	D1	D0

7) Read Display Data

Reads data (D0~D7) from the display data RAM.

After reading instruction, Y address is increased by 1 automatically.

RS	R/W	DB7	DB6	DB5	DB4	DB3	DB2	DB1	DB0
1	1	D7	D6	D5	D4	D3	D2	D1	D0

12.Reset and Initializing flow chart

12.1 Reset

The system can be initialized by setting RSTB terminal at low level when turning power on, receiving instruction from MPU.

When RSTB becomes low, following procedure is occurred.

- Display off
- Display start line register become set by 0. (Z-address 0)

While RSTB is low, No instruction except status read can be accepted. Therefore, execute other instructions after making sure that DB4 = 0 (clear RSTB) and DB7 = 0 (ready) by status read instruction. The Conditions of power supply at initial power up are shown as follow.

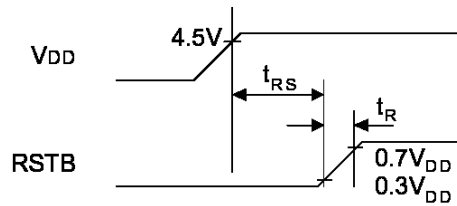

Item	Symbol	Min	Typ	Max	Unit
Reset time	t_{RS}	1.0	-	-	uS
Rise time	t_R	-	-	200	nS

12.2 Initializing flow chart

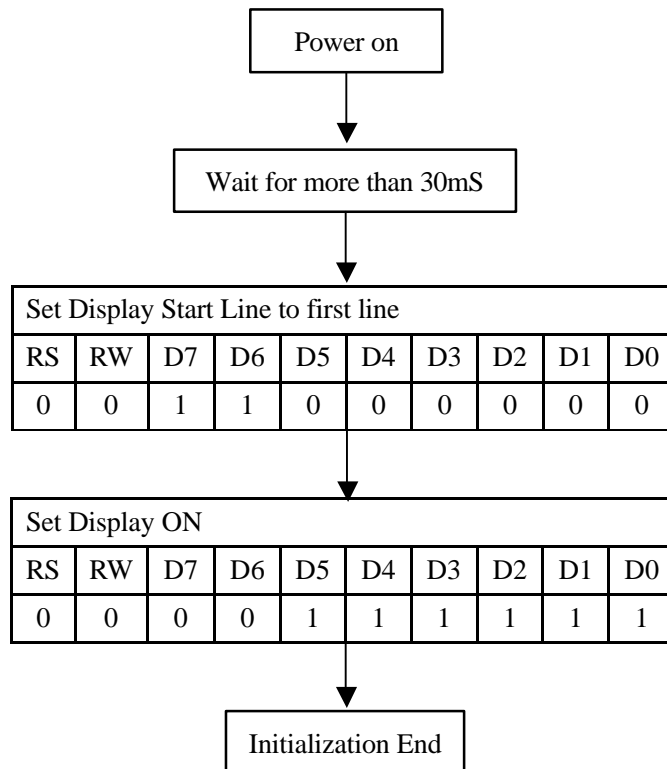

13. Display Data RAM map

Page	Lines	Column Address(0 ~63)										Data			
1st page(X=0)	Line 0→	0	1	1	1	0	0	0	0	1	0	0	0	←DB0(LSB)
	Line 1→	1	0	0	0	1	0	0	0	1	1	0	0	←DB1
	Line 2→	1	0	0	0	1	0	0	0	1	0	1	0	←DB2
	Line 3→	1	0	0	0	1	0	0	0	1	0	1	0	←DB3
	⋮	1	1	1	1	1	0	0	0	1	0	0	0	←DB4
	⋮	1	0	0	0	1	0	1	1	1	0	0	0	←DB5
	Line 7→	1	0	0	0	1	0	1	1	1	0	0	0	←DB6
2nd page(X=1)	Line 8→	0	0	0	0	0	0	0	0	0	0	0	0	←DB7(MSB)
	Line 8→	1	1	1	1	0	0	0	1	1	1	0	0	←DB0(LSB)
	Line 9→	1	0	0	0	1	0	0	1	0	0	1	0	←DB1
	Line 10→	1	0	0	0	1	0	0	1	0	0	1	0	←DB2
	⋮	1	1	1	1	0	0	1	1	1	0	1	0	←DB3
	⋮	1	0	0	0	1	0	0	1	0	0	1	0	←DB4
	⋮	1	0	0	0	1	0	0	1	0	0	1	0	←DB5
Line 15→	1	1	1	1	0	0	0	1	1	1	0	0	←DB6	
⋮	0	0	0	0	0	0	0	0	0	0	0	0	←DB7(MSB)	
⋮	⋮													
8th page(X=7)	Line 56→	1	0	0	0	1	0	0	0	0	0	0	0	←DB0(LSB)
	⋮	1	0	0	0	1	0	0	0	0	0	0	0	←DB1
	⋮	1	0	0	0	1	0	0	1	0	0	1	0	←DB2
	⋮	1	1	1	1	1	0	1	0	1	0	1	0	←DB3
	⋮	1	0	0	0	1	0	1	0	0	1	0	0	←DB4
	⋮	1	0	0	0	1	0	1	0	0	1	0	0	←DB5
	Line 62→	1	0	0	0	1	0	0	1	1	0	1	0	←DB6
Line 63→	0	0	0	0	0	0							←DB7(MSB)	

14. Revision records

Version	Ref.pages	Revision Items	Date
A00	All pages	New release	2011.05.27