

FREQUENCY MULTIPLEX PLL STEREO DECODER

The TDA1005A is a high quality PLL stereo decoder based on the frequency-division multiplex (f.d.m.) principle, performing:

- excellent ACI (Adjacent Channel Interference) and SCA (Storecast) rejection
- very low BFC (Beat-Frequency Components) distortion in the higher frequency region

The circuit incorporates the following features:

- with simplified peripheral circuitry the circuit can perform as a time-division multiplex (t.d.m.) decoder, for use in economic medium and low-class apparatus
- for car radios: operation at a supply voltage of 8 V
- extra pin for smooth mono/stereo take-over without "clicks"
- automatic mono/stereo switching (minimum switching level is 16 mV), controlled by both pilot signal and field strength level
- low distortion in the loop resonance frequency region (≈ 300 Hz; THD = 0,2% typ.)
- external adjustment for obtaining optimum channel separation in the complete receiver
- internal amplification: t.d.m., 7 dB; f.d.m., 10 dB
- driver for stereo indicator lamp
- externally switchable: VCO-off or mono condition
- guaranteed VCO capture range ($> 3,5\%$ or 2,7 kHz)

QUICK REFERENCE DATA

Supply voltage range	V_{8-16}		8 to 18 V	
Supply voltage	V_{8-16}	typ.	15	V
Ambient temperature	T_{amb}	typ.	25	$^{\circ}C$
Measured at $V_i(p-p) = 1$ V (MUX signal with 8% pilot)				
Channel separation at $f = 1$ kHz	α	typ.	50	55 dB
Carrier suppression				
at $f = 19$ kHz	α_{19}	typ.	36	36 dB
at $f = 38$ kHz	α_{38}	typ.	45	40 dB
at $f = 76$ kHz	α_{76}	typ.	80	75 dB
ACI rejection at $f = 114$ kHz	α_{114}	typ.	52	70 dB
SCA rejection at $f = 67$ kHz	α_{67}	typ.	85	90 dB
VCO capture range			$>$	3,5 %
Total harmonic distortion				
$f_m = 1$ kHz	THD	typ.	0,2	0,1 %
$f_m = 300$ Hz to 10 kHz	THD	typ.	0,2	0,1 %
BFC suppression	dB_{BFC}	$>$	40	60 dB

PACKAGE OUTLINES

TDA1005A ; 16-lead DiL; plastic (SOT-38).

TDA1005AT; 16-lead flat pack; plastic (SO-16; SOT-109A).

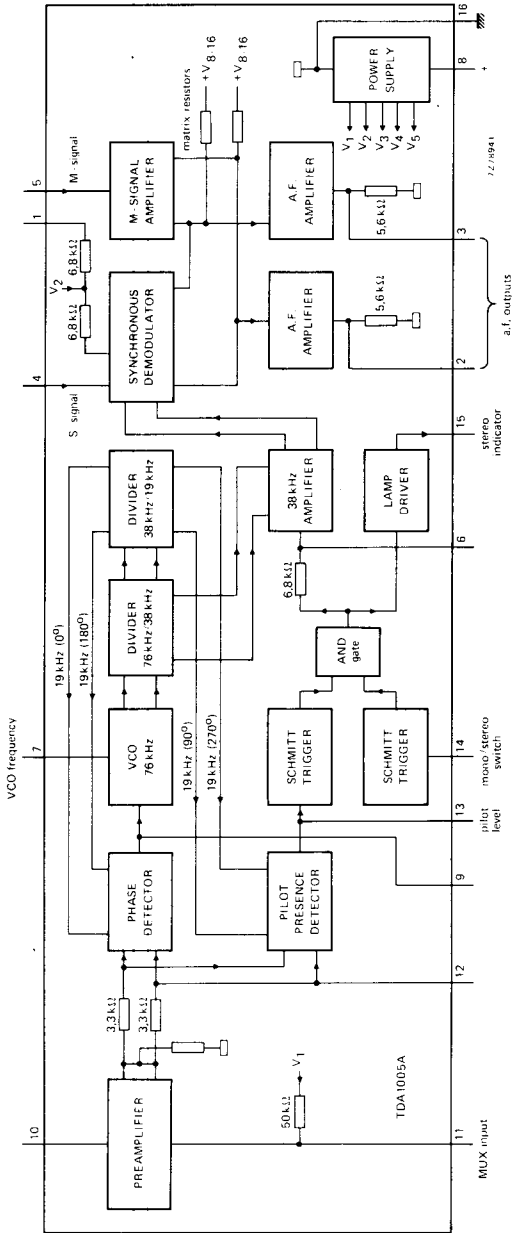

Fig. 1 Block diagram.

262

RATINGS

Limiting values in accordance with the Absolute Maximum System (IEC 134)

Supply voltage	V ₈₋₁₆	max.	18 V
Indicator lamp voltage	V ₁₅₋₁₆	max.	22 V
Mono/stereo switching voltage	V ₁₄₋₁₆	max.	4 V
Indicator lamp current	I ₁₅	max.	100 mA
Indicator lamp turn-on current (peak value)	I _{15M}	max.	200 mA
Total power dissipation	see derating curve Fig. 2		
Storage temperature	T _{stg}	-55 to + 150 °C	
Operating ambient temperature (see also Fig. 2)	T _{amb}	-25 to + 150 °C	

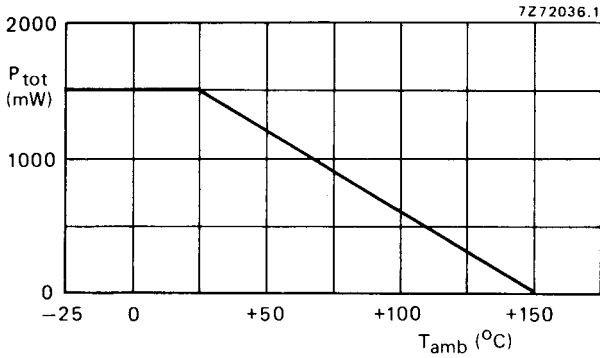

Fig. 2 Power derating curve.



A.C. CHARACTERISTICS and APPLICATION INFORMATION

T_{amb} = 25 °C; V₈₋₁₆ = 15 V (unless otherwise specified); see also Fig. 7 and Fig. 10.

	note	pin	parameter		t.d.m.	f.d.m.	unit				
Channel separation see Figs 23 and 24	1, 2	2, 3	α	>	40	45	dB				
				typ.	50	55	dB				
F.M.—I.F. roll-off correction range	1, 2				48 to 72	—	kHz				
Input MUX-voltage; L = 1; R = 1 for THD < 0,35%	1, 2	11	V _{i(p-p)}	typ.	1	1	V				
Input impedance		11	Z _i	>	35	35	k Ω				
				typ.	50	50	k Ω				
Voltage gain per channel	1, 2		G _v	typ.	7	10	dB				
Channel balance	1, 2		$\pm \Delta G_v$	<	1	1	dB				
Output voltage (r.m.s. value) L = 1; R = 1	1, 2	2	V _{2-16(rms)}	>	0,61	0,97	V				
		3	V _{3-16(rms)}	>	0,61	0,97	V				
Output impedance	3	2, 3	Z _o	typ.	5,6	5,6	k Ω				
					4 to 7	4 to 7	k Ω				
Total harmonic distortion; see Figs 25 and 26	1	2, 3	THD	typ.	0,2	0,1	%				
				<	0,35	0,35	%				
				typ.	0,2	0,1	%				
Carrier suppression	1	2, 3	α_{19}	typ.	36	36	dB				
				typ.	60	60	dB				
				>	40	38	dB				
				>	72	72	dB				
				typ.	46	56	dB				
				typ.	59	61	dB				
				typ.	80	75	dB				
				ACI rejection	4	2, 3	α_{114}	typ.	52	70	dB
								typ.	55	74	dB
				SCA rejection at f = 67 kHz	5	2, 3	α_{67}	typ.	85	90	dB
Ripple rejection; f = 100 Hz; V _{8-16(rms)} = 200 mV			RR	>	40	40	dB				
				typ.	50	50	dB				

	note	pin	parameter	t.d.m.	f.d.m.	unit
VCO; adjustable with R ₇₋₁₆ nominal frequency	6		f _{VCO} typ.	76	76	kHz
capture range (deviation from 76 kHz centre frequency)	6		>	3,5	3,5	%
19 kHz pilot signal of 32 mV						
temperature coefficient uncompensated	6		-TC typ.	450.10 ⁻⁶	450.10 ⁻⁶	K ⁻¹
compensated	6		± TC typ.	200.10 ⁻⁶	200.10 ⁻⁶	K ⁻¹
Stereo/mono switch when equal to 19 kHz pilot-tone threshold voltage; adjustable with R ₁₃₋₈	7	11	V _i	10 to 100	10 to 100	mV
when equal to threshold voltage at R ₁₃₋₈ = 620 kΩ for switching to stereo		11	V _i	7 to 16	7 to 16	mV
for switching to mono		11	V _i <	5	5	mV
hysteresis	8	11	ΔV _i typ.	2,5	2,5	dB
Smooth take-over circuit full mono	8	6	V ₆₋₁₆ <	0,65	0,65	V
full stereo	8	6	V ₆₋₁₆ >	1,3	1,3	V

Notes

- V_{i(p-p)} = 1 V (MUX signal with 8% pilot level).
- f_m = 1 kHz.
- At supply voltages of 8 to 11 V, resistors of 5,6 kΩ have to be connected from ground to pins 2 and 3.
- Measured with a composite input signal: L = R; f_m = 1 kHz; 90% M-signal; 9% pilot signal; 1% spurious signal of 110 kHz (for α₁₁₄) or 186 kHz (for α₁₉₀).

ACI suppression is defined as: $20 \log \frac{V_O \text{ (at 4 kHz)}}{V_O \text{ (at 1 kHz)}}$

- Measured with a composite input signal: L = R; f_m = 1 kHz; 80% S-signal; 9% pilot signal; 10% SCA carrier (67 kHz); d₁₃ = $20 \log \frac{V_O \text{ (at 9 kHz)}}{V_O \text{ (at 1 kHz)}}$

6. See also Figs 7 and 10; compensated with RC network on pin 7.

7. Adjustable with R₁₃₋₈; see also Fig. 28; for field strength dependent input (pin 14) see next page.

8. $\Delta V_i = 20 \log \frac{V_{11-16} \text{ (mono/stereo)}}{V_{11-16} \text{ (stereo/mono)}}$

For additional circuitry on pin 6 see Figs 7 and 10; for graph see Fig. 29.

9. For example of notch filter see Fig. 6.

205



D.C. CHARACTERISTICS

$T_{amb} = 25\text{ }^{\circ}\text{C}$; $V_{8-16} = 15\text{ V}$ (unless otherwise specified)

Supply voltage range	V_{8-16}	8 to 18 V *
Total current (except indicator lamp)	I_g	typ. 21 mA
Power dissipation (operating) at lamp current $I_{15} = 100\text{ mA}$; $V_{8-16} = 18\text{ V}$	P_{tot}	< 570 mW
Saturation voltage of lamp driver at $I_{15} = 100\text{ mA}$	V_{15-16}	typ. 0,9 V
Maximum lamp driver voltage	V_{15-16}	< 22 V
Switching voltage		
to mono	V_{14-16}	> 1,2 V **
to stereo	V_{14-16}	< 0,65 V
hysteresis	V_{14-16}	typ. 0,2 V

APPLICATION NOTES

1. Switching-off the VCO

If the internal gain is used with A.M. reception, the VCO can be switched off by connecting pin 9 via a 100 k Ω resistor to ground (no h.f. signal on the leads), or connecting pin 7 to ground.

2. Mono button

The decoder can be switched to the mono position by connecting pin 12 to ground. The VCO then remains operational so this possibility cannot be used with A.M. reception.

3. Economic periphery

- a. For a fixed stereo switching level of $\leq 16\text{ mV}$ a resistor of 620 k Ω can be connected between pin 13 and positive supply (+) instead of a potentiometer in series with a resistor.
- b. The 10 k Ω resistor connected in parallel with the stereo indicator lamp can be omitted, however, some TDA1005A circuits will switch to mono during lamp failure.
- c. The 10 μF capacitor in series with a 1 k Ω resistor at pin 9 can be decreased to a 1 μF capacitor, bearing in mind that the distortion will increase, especially around loop resonance.
- d. A MUX-input filter is not needed, if i.f. roll-off starts at a frequency of 62 kHz.

4. Printed-circuit boards

For both the f.d.m. and t.d.m. stereo decoder circuits a printed-circuit board layout is given as an example (Figs 8 and 11). Also for an active filter, which is mainly used with a t.d.m. decoder, a printed-circuit board layout is given in Fig. 4.

5. Notch filter

If attention has to be paid for suppression of the 57 kHz signal (T.W.S. = Traffic Warning System) and the 19 kHz signal, an input filter can be used as given in Fig. 6.

* At supply voltages of 8 to 11 V, resistors of 5,6 k Ω have to be connected from ground to pins 2 and 3.

** Maximum voltage for safe operation: $V_{14-16} < 4\text{ V}$.

APPLICATION INFORMATION

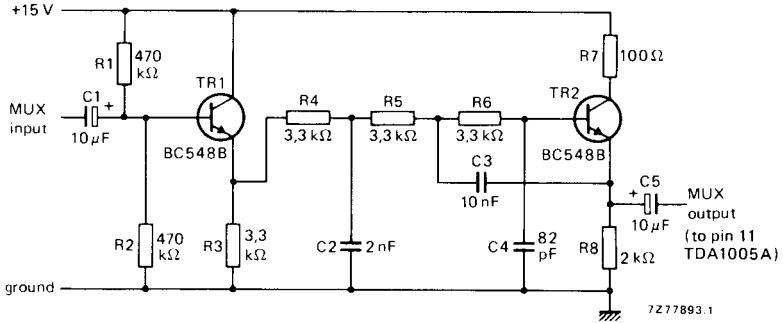

Fig. 3 Active filter circuit diagram.

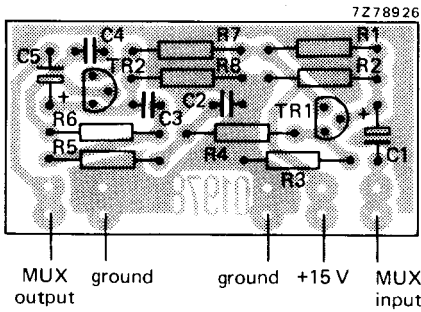

Fig. 4 Printed-circuit board component side, showing component layout.

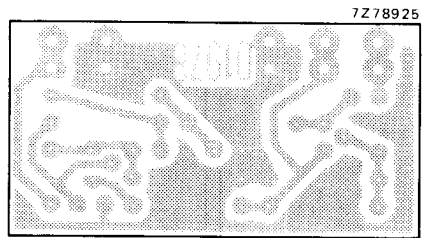
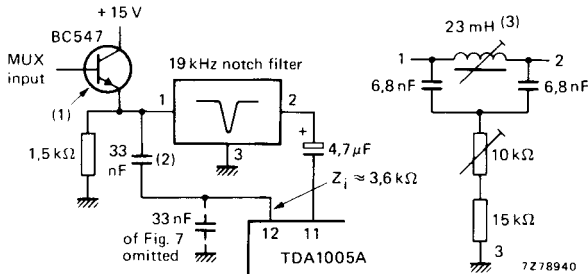

Fig. 5 Printed-circuit board showing track side.



- (1) Transistor to achieve low impedance driving of notch filter.
- (2) 33 nF will give common mode suppression of 19 kHz.
- (3) Coil: TOKO 10 PA, 700 turns, ϕ 0,07 mm Cu; case type: P06-0114; drumcore: AN01-0021; base 5 pins type: 07-0084-02; core type CAN02-0029.

Fig. 6 Example of using a 19 kHz tuned notch filter; for other input structures see Figs 13 to 21.

207



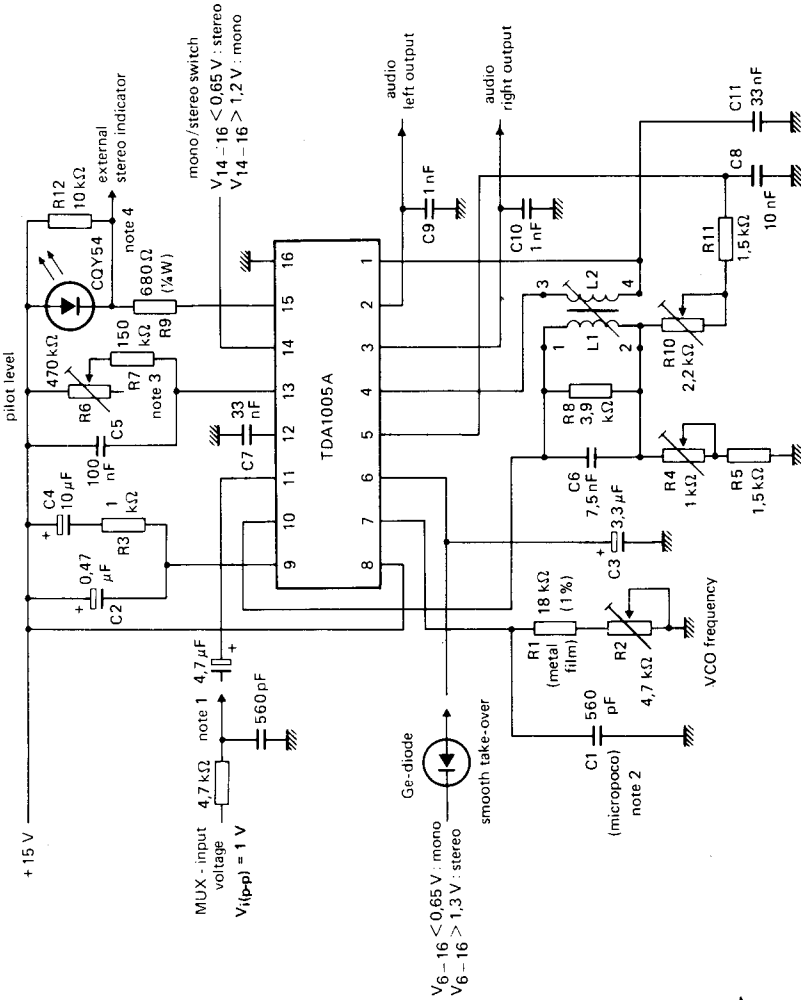

7276461.3

channel separation

Notes

1. For other input structures see Figs 13 to 21; shown here is with RC-filter (Fig. 15).
2. The microproc capacitor has a temperature coefficient of $125 \cdot 10^{-6} \pm 60 \cdot 10^{-6} \text{ K}^{-1}$.
3. In simplified circuits a fixed resistor (e.g. 620 kΩ) can be used for a guaranteed switching level of $\leq 16 \text{ mV}$.
4. Either the LED circuit or an external stereo indicator can be used.

Coil data:
 $L_{1-2} = 2,6 \text{ mH}$
 $Q_{1-2} = 35; Q_{\text{min}} = 30$
 $N_{1-2} = 357\frac{1}{2} \text{ turns;}$
 $N_{3-4} = 297\frac{1}{2} \text{ turns;}$
 scrambled wound with
 wire diameter 0,09 mm,
 $\frac{E_{3-4}}{E_{1-2}} \times 100\% = 82\%$

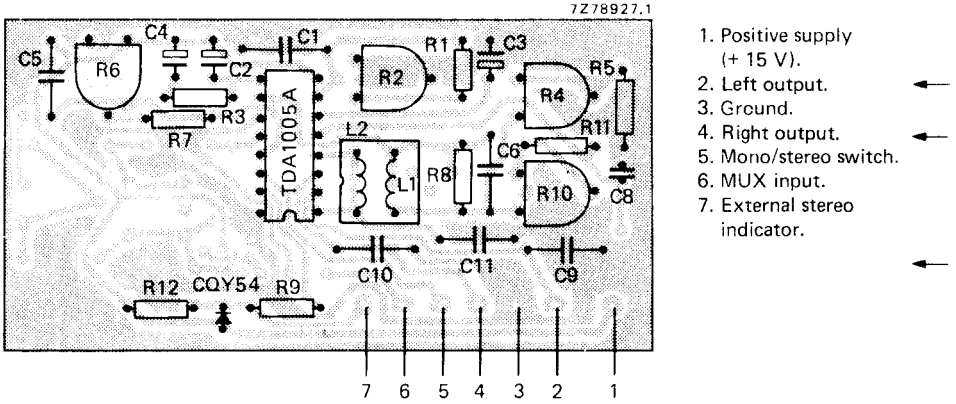

Fig. 8 Printed-circuit board component side of an f.d.m. decoder, showing component layout. For circuit diagram see Fig. 7.

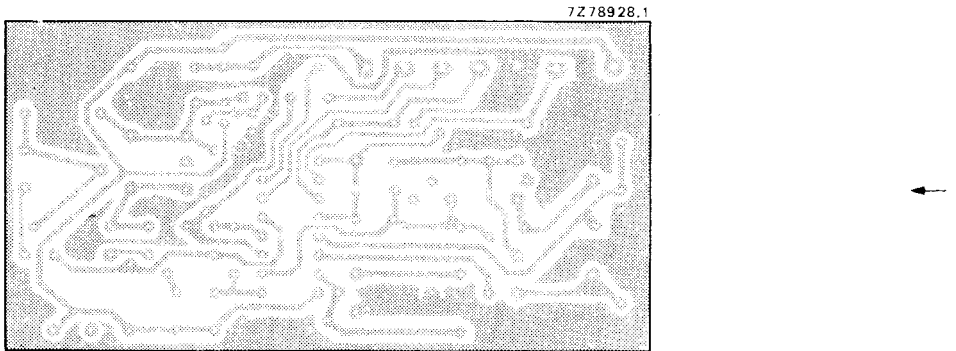
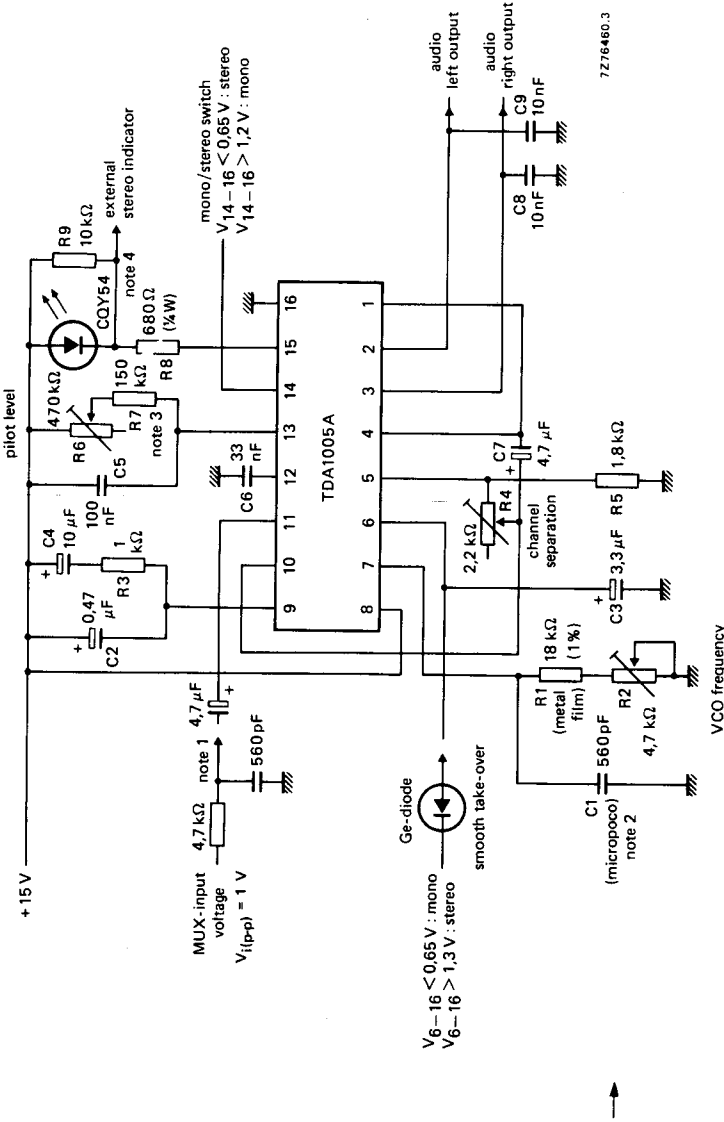

Fig. 9 Printed-circuit board showing track side.





7Z76460.3

Notes

1. For other input structures see Figs 13 to 21; shown here is with RC-filter (Fig. 15).
2. The microproc capacitor has a temperature coefficient of $125 \cdot 10^{-6} \pm 60 \cdot 10^{-6} \text{ } ^\circ\text{C}^{-1}$.
3. In simplified circuits a fixed resistor (e.g. 620 kΩ) can be used for a guaranteed switching level of $\leq 16 \text{ mV}$.
4. Either the LED circuit or an external stereo indicator can be used.

Fig. 10 Basic application circuit of a time-division multiplex (t.d.m.) stereo decoder.

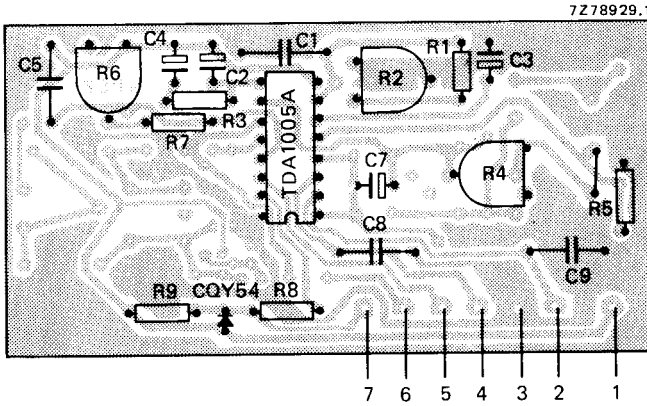

Fig. 11 Printed-circuit board component side of a t.d.m. decoder, showing component layout. For circuit diagram see Fig. 10.

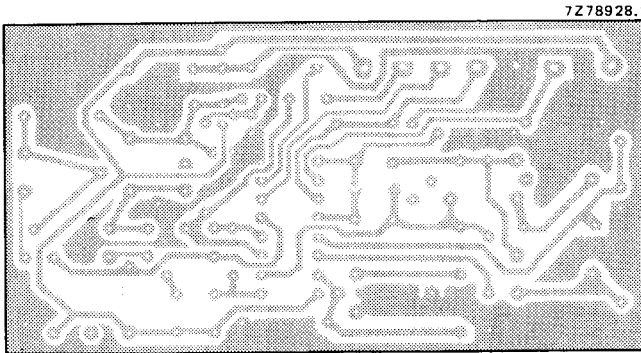

Fig. 12 Printed-circuit board showing track side.

112



INPUT STRUCTURES (see also Figs 7 and 10)

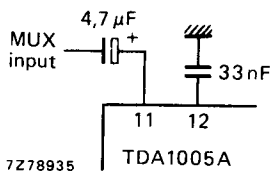

Fig. 13 Without filtering.

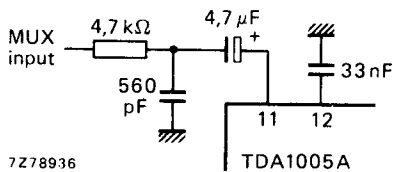

Fig. 15 With RC-filter for achieving i.f. roll-off (typ. 62 kHz).

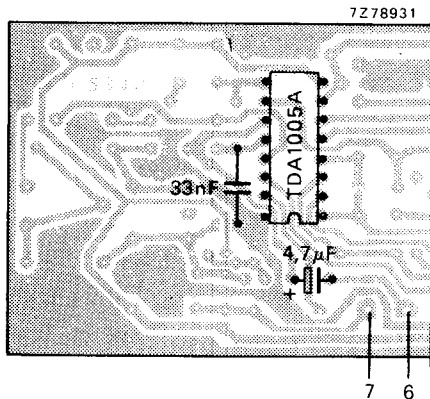

Fig. 14 Printed-circuit board component side, showing component layout of Fig. 13.

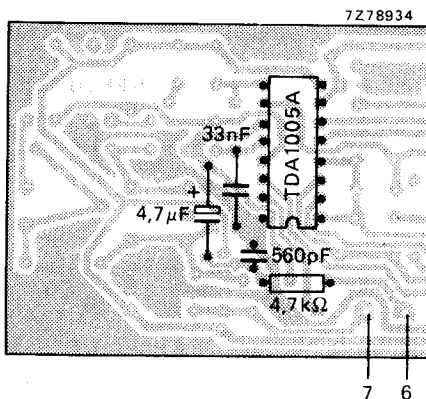

Fig. 16 Printed-circuit board component side, showing component layout of Fig. 15.

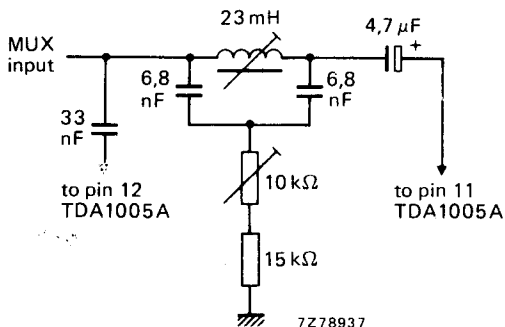

Fig. 17 With 19 kHz notch filter.

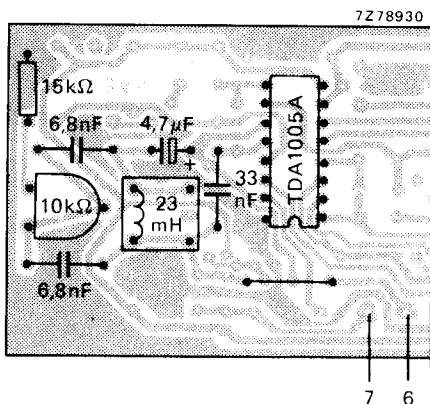

Fig. 18 Printed-circuit board component side, showing component layout of Fig. 17.

2012

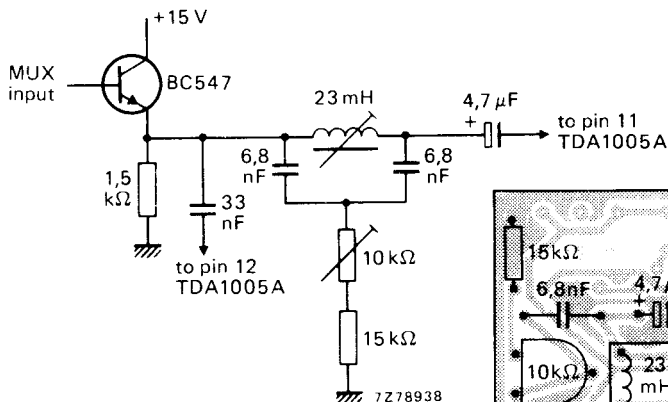

Fig. 19 With buffer stage (to achieve low impedance driving of notch filter; see Fig. 6) and 19 kHz notch filter.

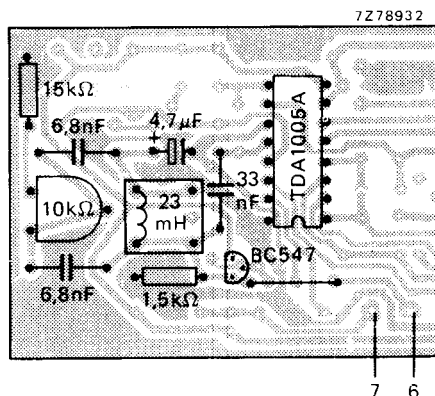

Fig. 20 Printed-circuit board component side, showing component layout of Fig. 19.

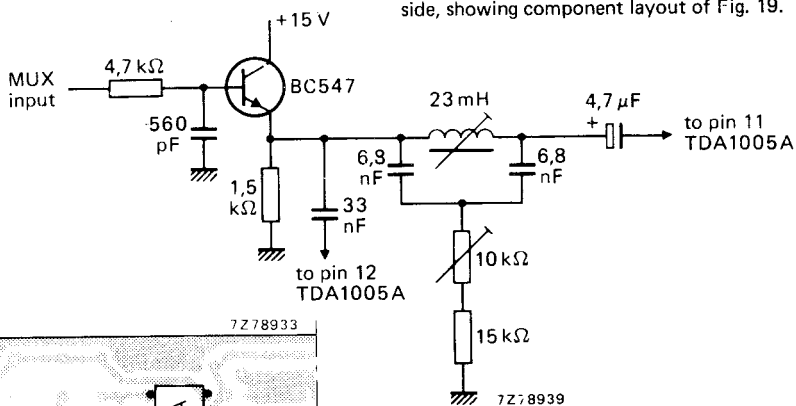

Fig. 21 With RC-filter, buffer stage and 19 kHz notch filter.

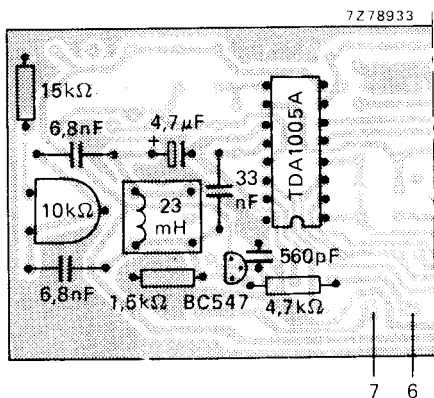
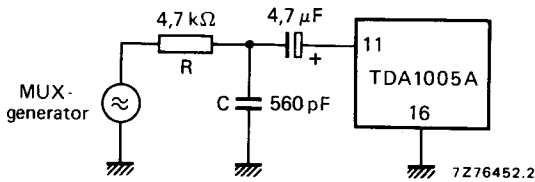
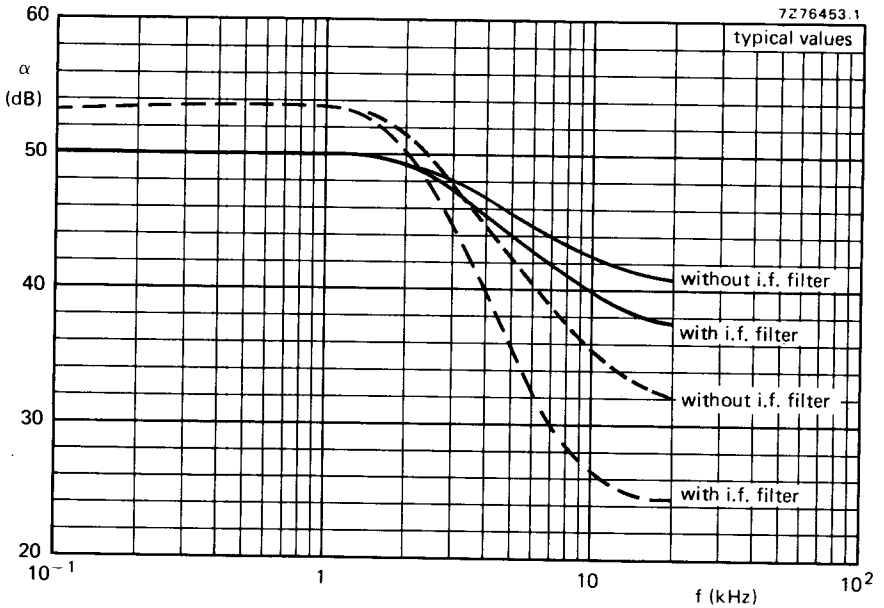

Fig. 22 Printed-circuit board component side, showing component layout of Fig. 21.



- time-division multiplex system; adjusted at 1 kHz (R4 in Fig. 10)
- - - frequency-division multiplex system; adjusted at 1 and 5 kHz (R4 and R10 in Fig. 7)

Conditions: $V_{B-16} = 15 \text{ V}$; $V_{i(p-p)} = 1 \text{ V}$.

Note: RC-filter for simulating the i.f. roll-off (typ. 62 kHz).

Fig. 23 Channel separation as a function of frequency.

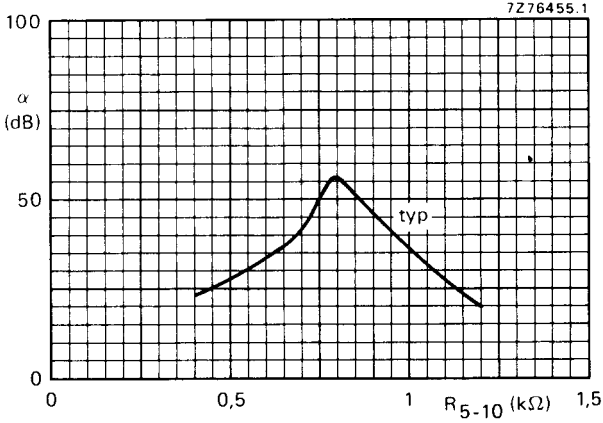

Fig. 24 Channel separation at $f = 1$ kHz as a function of resistance between pins 5 and 10 for a t.d.m. system. For test circuit see Fig. 23. ←

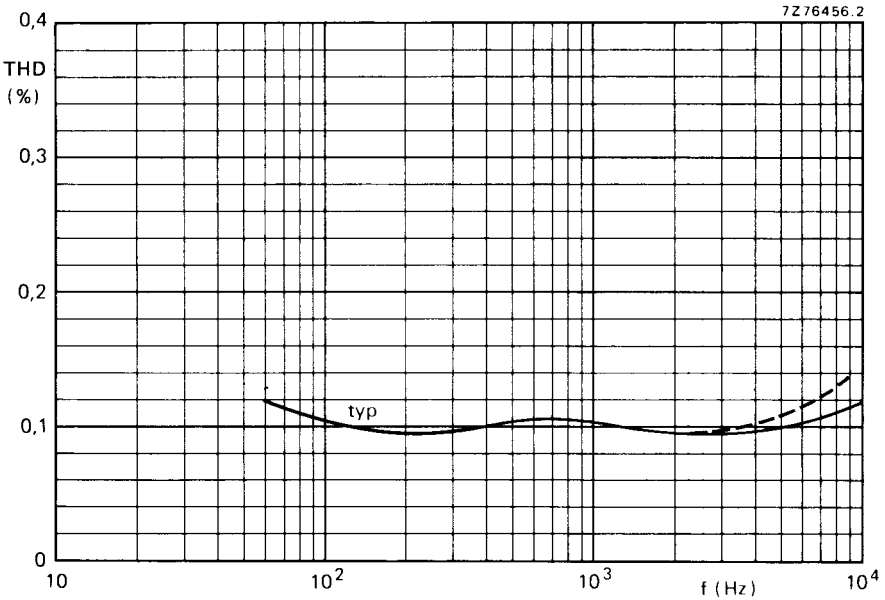
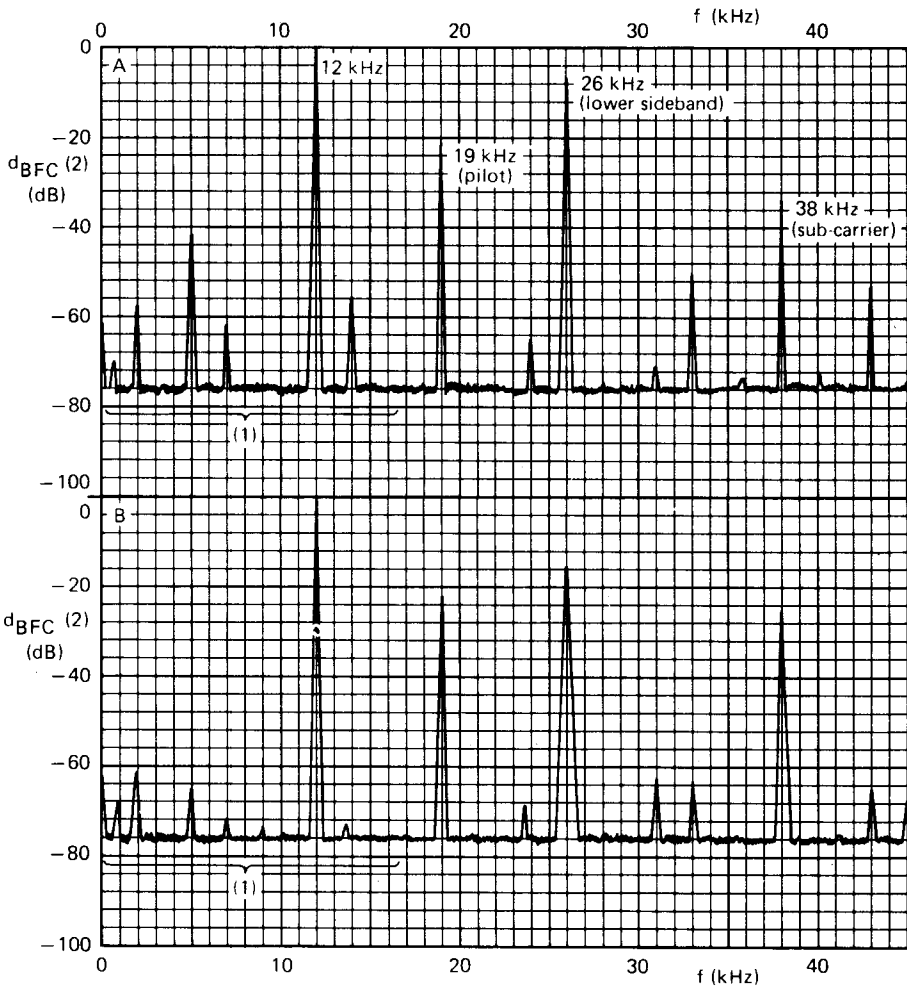

Fig. 25 Distortion as a function of audio frequency; $R = 1$; $L = 0$; $V_{8-16} = 15$ V; $V_{2-16} = V_{3-16} = 1$ V (r.m.s.). - - - t.d.m. system; — f.d.m. system. ←





(1) Audible interferences (BFC-distortion) and desired 12 kHz signal.

$$(2) d_{BFC} = 20 \log \frac{V_{BFC}}{V \text{ (at 12 kHz)}}$$

Fig. 26 Spectrum at the decoder outputs; A for t.d.m.; B for f.d.m. $V_{i(p-p)} = 1 \text{ V}$; $R = 1$; $L = 0$; $m = 90\%$ for $f = 12 \text{ kHz}$; $m = 10\%$ for $f = 19 \text{ kHz}$.

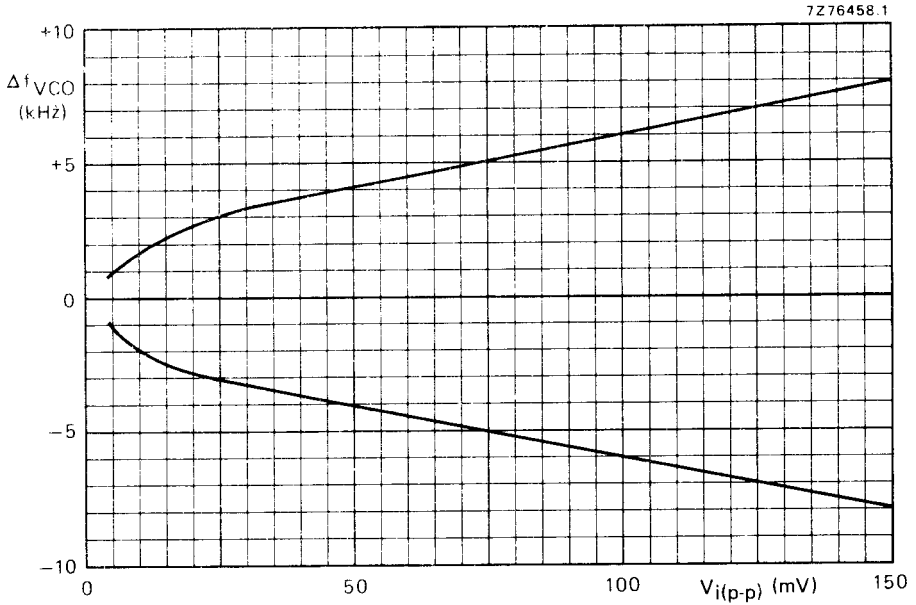

Fig. 27 Typical values of the capture range of the oscillator as a function of the pilot threshold voltage at MUX-input.

$V_{8-16} = 15 \text{ V}$; $\Delta f_{VCO} = f_{VCO} - 76 \text{ kHz}$ where: f_{VCO} = modulated, free-running oscillator frequency;
 Δf_{VCO} = maximum f_{VCO} deviation which will be captured if pilot signal (pin 11) is switched-on.

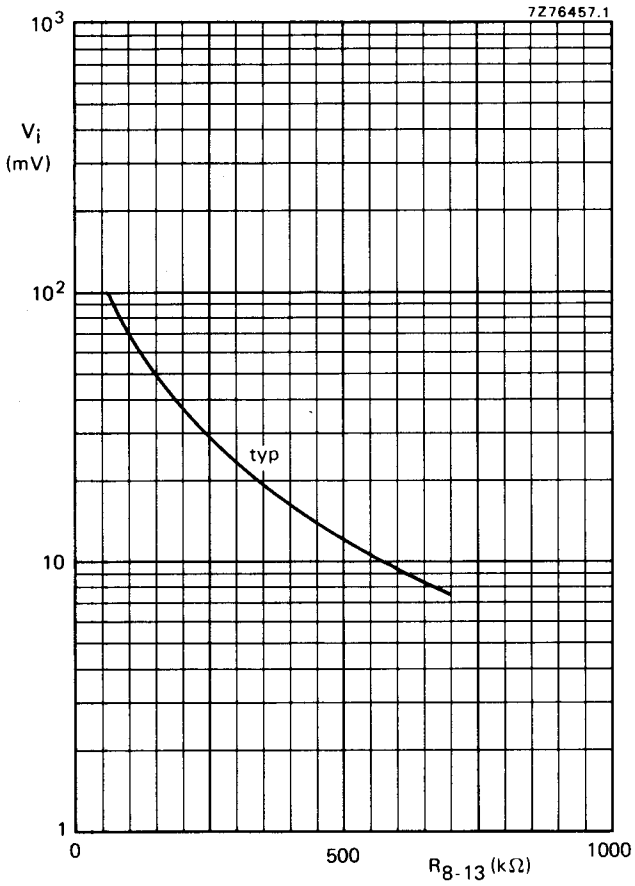

Fig. 28 Pilot input voltage switching level (stereo 'on') as a function of resistance between pins 8 and 13.

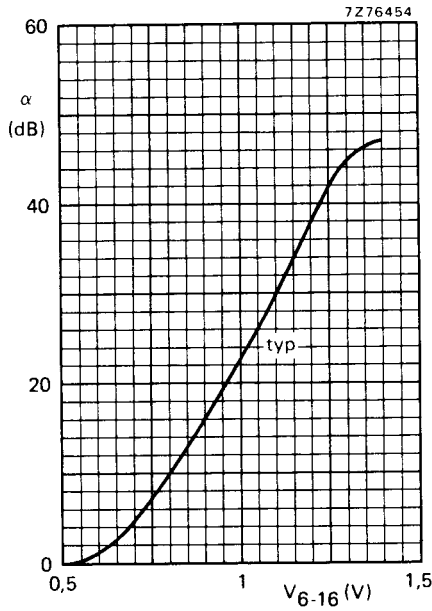

Fig. 29 Channel separation as a function of V_{6-16} at 1 kHz (smooth take-over).