

MITSUBISHI LINEAR ICs  
**M51724P,FP**

6249826 MITSUBISHI ELEK (LINEAR)

80C 09018 D

T-52-13-25

**3-PHASE BRUSHLESS MOTOR PRE-DRIVER**

**DESCRIPTION**

The M51724P,FP are semiconductor integrated circuits designed for use in 3-phase DC brushless motor.

**FEATURES**

- Suitable for various kind of motor system by selecting the external power transistors
- Internal current distribution circuit
- Good balance in output current between each phase
- Few externally connected parts

**APPLICATION**

Brushless motor driver for VTR, cassette tape deck, floppy-disk drive.

**RECOMMENDED OPERATING CONDITIONS**

- Supply voltage range ..... 10V~20V
- Rated supply voltage ..... 15V

**PIN CONFIGURATION (TOP VIEW)**

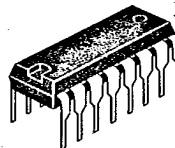
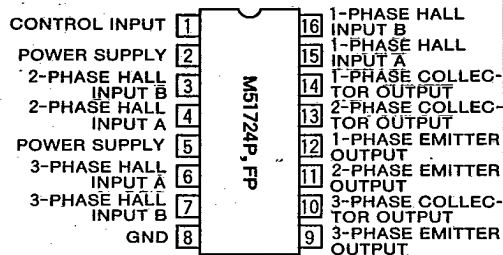

16-pin molded plastic DIP



16-pin molded plastic FLAT

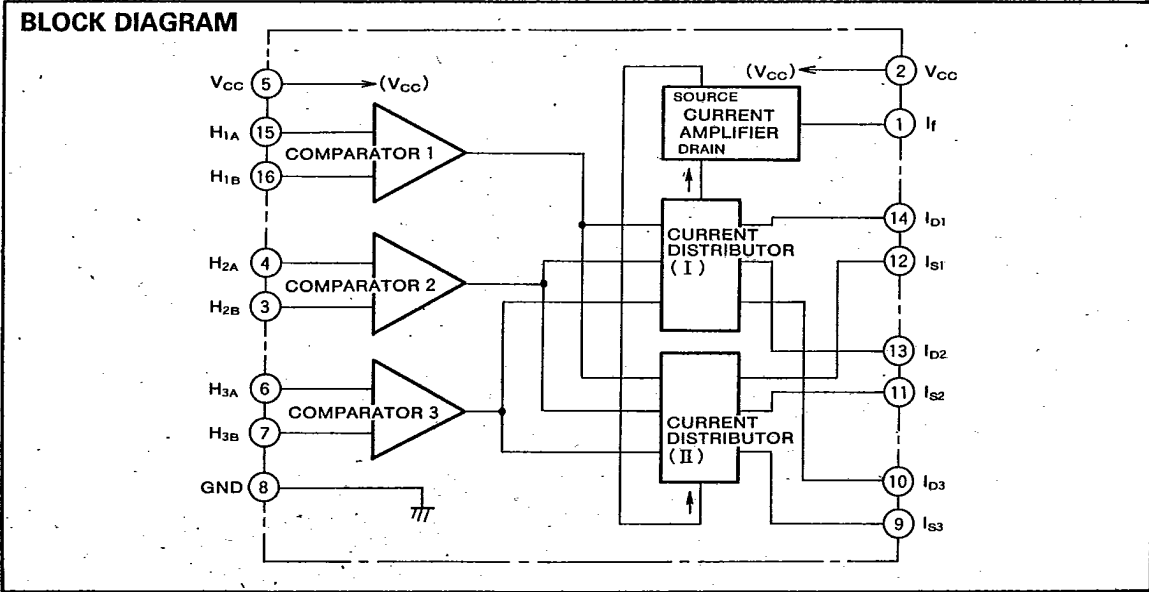

**3-PHASE BRUSHLESS MOTOR PRE-DRIVER**

**ABSOLUTE MAXIMUM RATINGS** ( $T_a=25^\circ\text{C}$ , unless otherwise noted)

Symbol	Parameter	Conditions	Ratings	Unit
$V_{CC}$	Supply voltage		20	V
$I_f$	Control input current		1	mA
$V_D$	Applied voltage at collector output pin		24	V
$V_S$	Applied voltage at emitter output pin		6.5	V
$V_H$	Applied voltage at hall output pins		6.5	V
$f_{in}$	Hall input frequency		DC~1	kHz
$P_d$	Power dissipation	( )=M51724FP	900(540)	mW
$K_\theta$	Thermal derating ( $T \geq 25^\circ\text{C}$ )	( )=M51724FP	110(185)	$^\circ\text{C/W}$
$T_{opr}$	Operating temperature		-10~+50	$^\circ\text{C}$
$T_{stg}$	Storage temperature		-40~+125	$^\circ\text{C}$

**ELECTRICAL CHARACTERISTICS** ( $T_a=25^\circ\text{C}$ ,  $V_{CC}=15\text{V}$ , unless otherwise noted)

Symbol	Parameter	Test conditions	Limits			Unit
			Min	Typ	Max	
$I_{CC}$	Circuit current		5	12	27	mA
$V_{offset}$	Comparator input offset voltage			5	20	mV
$K_D$	Collector output current gain		10	15	20	A/A
$K_S$	Emitter output current gain		11	16	21	A/A
$I_{D(max1)}$	Maximum output current of collector output (1)		3	4		mA
$I_{D(max2)}$	Maximum output current of collector output (2)		5.5	7		mA
$I_{S(max1)}$	Maximum output current of emitter output (1)		3	4		mA
$I_{S(max2)}$	Maximum output current of emitter output (2)		5	7		mA
$M_D$	Current gain ratio between collector output phases		0.75	1	1.33	A/A
$M_S$	Current gain ratio between emitter output phases		0.75	1	1.33	A/A
$I_{in}$	Comparator input current		0.1	1.5	6	$\mu\text{A}$
$I_{LD}$	Collector output leak current				200	nA
$I_{LS}$	Emitter output leak current				200	nA

**TYPICAL CHARACTERISTICS** ( $T_a=25^\circ\text{C}$ , unless otherwise noted)

**THERMAL DERATING (MAXIMUM RATING)**

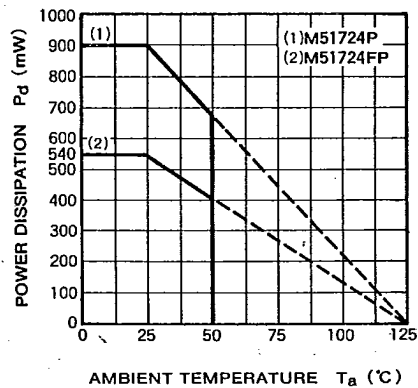

**CIRCUIT CURRENT VS. SUPPLY VOLTAGE**

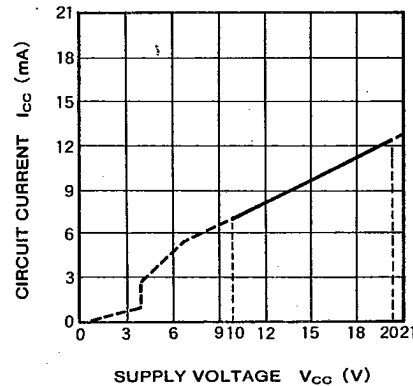

**3-PHASE BRUSHLESS MOTOR PRE-DRIVER**

**COLLECTOR OUTPUT CURRENT VS. CONTROL INPUT CURRENT**

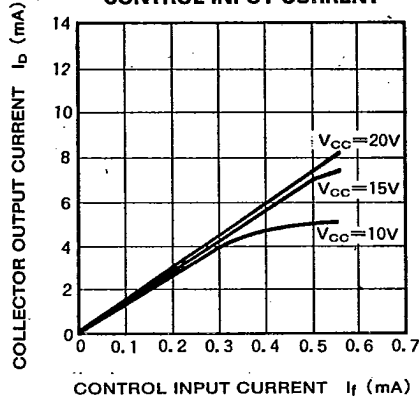

Note. when collector output 1 system and emitter output 2 system are ON

**EMITTER OUTPUT CURRENT VS. CONTROL INPUT CURRENT**

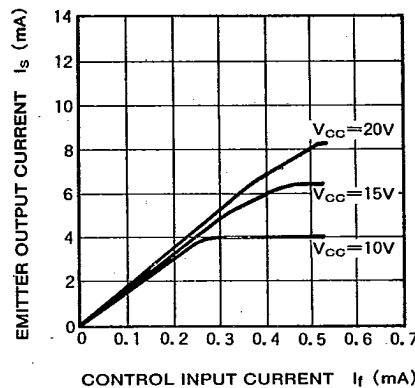

Note. when collector output 2 system and emitter output 1 system are ON

**INPUT/OUTPUT TIMING CHART OF THE M51724P,FP**

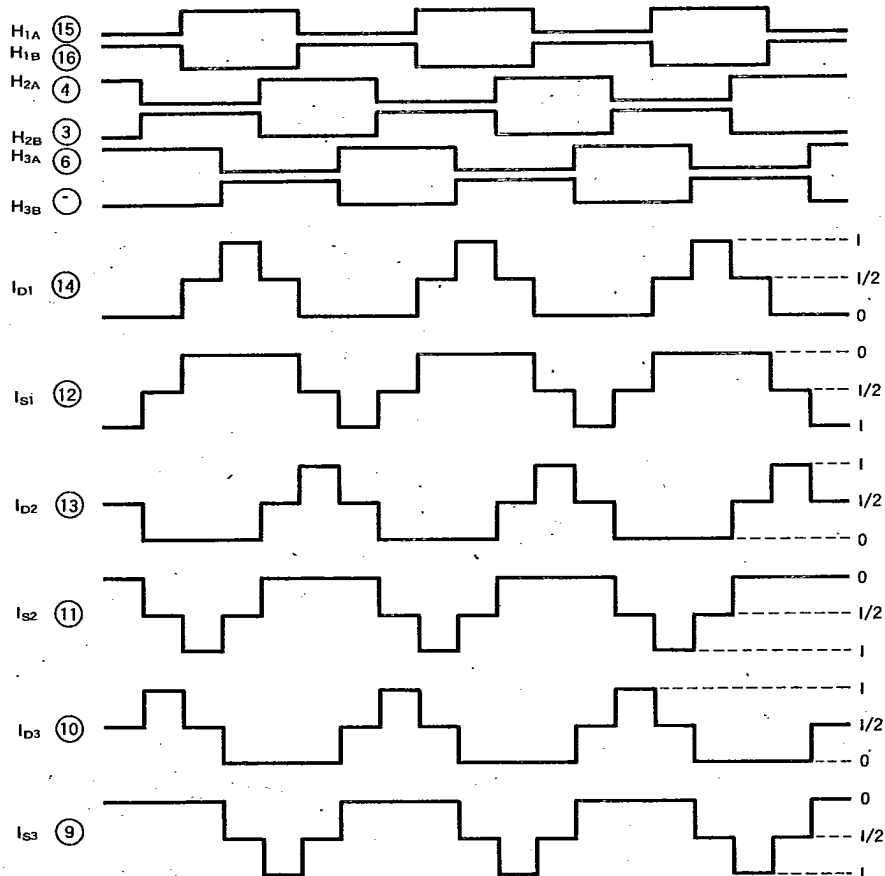

Note : 1. In the output current value ( $I_b$ ,  $I_s$ ), + indicates source current and - indicates sink current.  
 2. All the input pins are biased.  
 3. Care must be taken to connect a load (low impedance) to all the output pins according to the current at the control input Pin ①.

3-PHASE BRUSHLESS MOTOR PRE-DRIVER

APPLICATION EXAMPLE

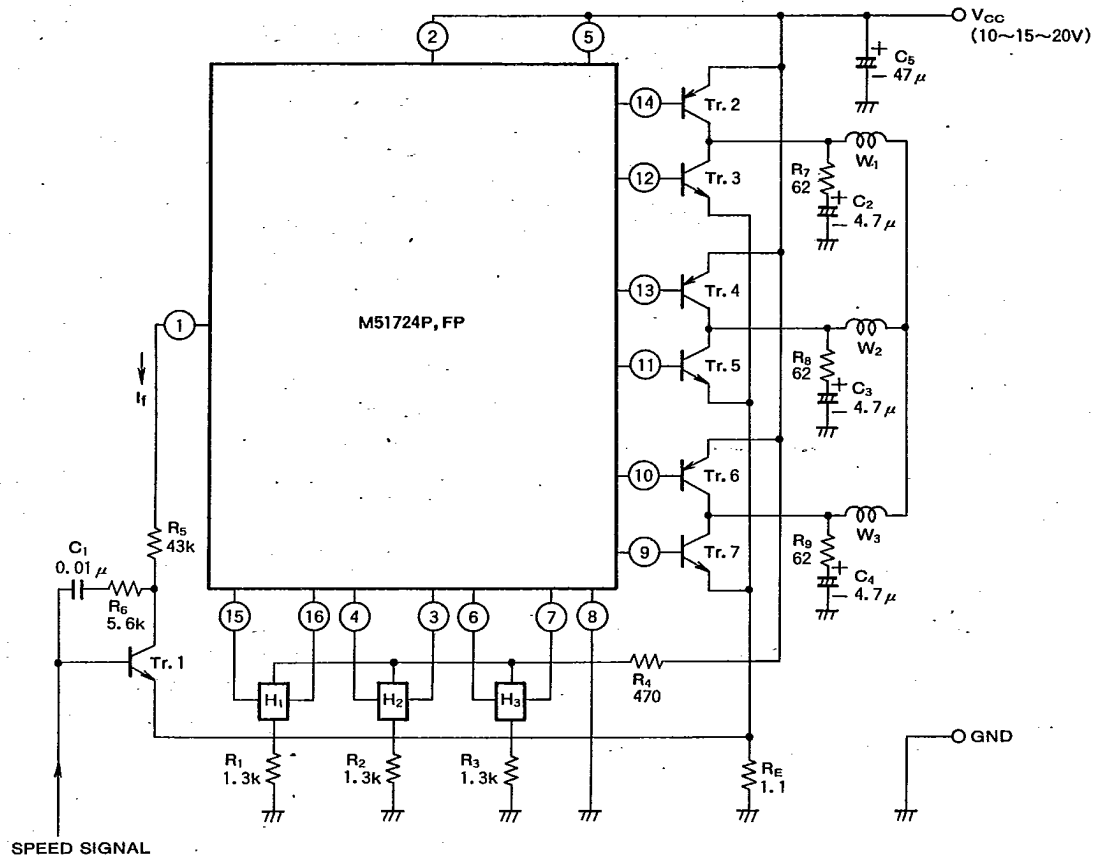

※All constants are tentative.

Unit Resistance : Ω  
Capacitance : F

NOTE :

1. R<sub>1</sub>~R<sub>4</sub> : For hall element bias
2. R<sub>5</sub> : For output (input) current limiting
3. R<sub>6</sub>, C<sub>1</sub> : For oscillation prevention
4. R<sub>7</sub>~R<sub>9</sub>, C<sub>2</sub>, C<sub>4</sub> : For reduction of driver noise
5. C<sub>5</sub> : For power supply stabilizing
6. R<sub>E</sub> : For current feedback
7. Tr. 1 : Control transistor (S. S. )
8. Tr. 2~Tr. 7 : Power transistors
9. H<sub>1</sub>~H<sub>3</sub> : Hall elements for position detection
10. The same power supply (V<sub>CC</sub>) must be connected to Pin ② and Pin ⑤.