

# DATA SHEET

## **TDA2549**

I.F. amplifier and demodulator for  
multistandard TV receivers

Product specification  
File under Integrated Circuits, IC02

April 1985

# I.F. amplifier and demodulator for multistandard TV receivers

## TDA2549

### GENERAL DESCRIPTION

The TDA2549 is a complete i.f. circuit with a.f.c., a.g.c., demodulation and video preamplification facilities for multistandard television receivers. It is capable of handling positively and negatively modulated video signals in both colour and black/white receivers.

### Features

- Gain-controlled wide-band amplifier providing complete i.f. gain
- Synchronous demodulator for positive and negative modulation
- Video preamplifier with noise protection for negative modulation
- Auxiliary video input and output (75  $\Omega$ )
- Video switch to select between auxiliary video input signal and demodulated video signal
- A.F.C. circuit with on/off switch and inverter switch
- A.G.C. circuit for positive modulation (mean level) and negative modulation (noise gate)
- A.G.C. output for controlling MOSFET tuners

### QUICK REFERENCE DATA

Supply voltage (pins 13 and 21)	$V_P = V_{13;21-3}$	typ.	12	V
Supply current (pins 13 and 21)	$I_P = I_{13;21-3}$	typ.	82	mA
I.F. input signal at $V_o = 2$ V (between pins 6 and 7)	$V_i = V_{6-7}$	typ.	50	$\mu$ V
Video output voltage at $V_i = 0$ V (between pins 22 and 3)				
positive modulation	$V_o = V_{22-3}$	typ.	2	V
negative modulation	$V_o = V_{22-3}$	typ.	4	V
Gain control range	$G_v$	typ.	74	dB
Signal-to-noise ratio at $V_i = 10$ mV	S/N	typ.	57	dB
A.F.C. output voltage swing (pin 15)	$V_{15-3}$	min.	10	V
Max. tuner a.g.c. output current (pin 10)	$I_{10}$	min.	0,3	mA
Video bandwidth (3 dB)	B	typ.	5,5	MHz
Auxiliary video input voltage (pin 12) at $V_o = 2$ V (peak-to-peak value)	$V_{12-3(p-p)}$	typ.	1	V
Auxiliary video output impedance (pin 14)	$ Z_{14-3} $	typ.	7	$\Omega$
Auxiliary video output voltage (pin 14)	$V_{14-3}$	typ.	2	V

### PACKAGE OUTLINE

24-lead DIL; plastic (SOT101A); SOT101-1; 1996 November 19.

I.F. amplifier and demodulator for multistandard TV receivers

TDA2549

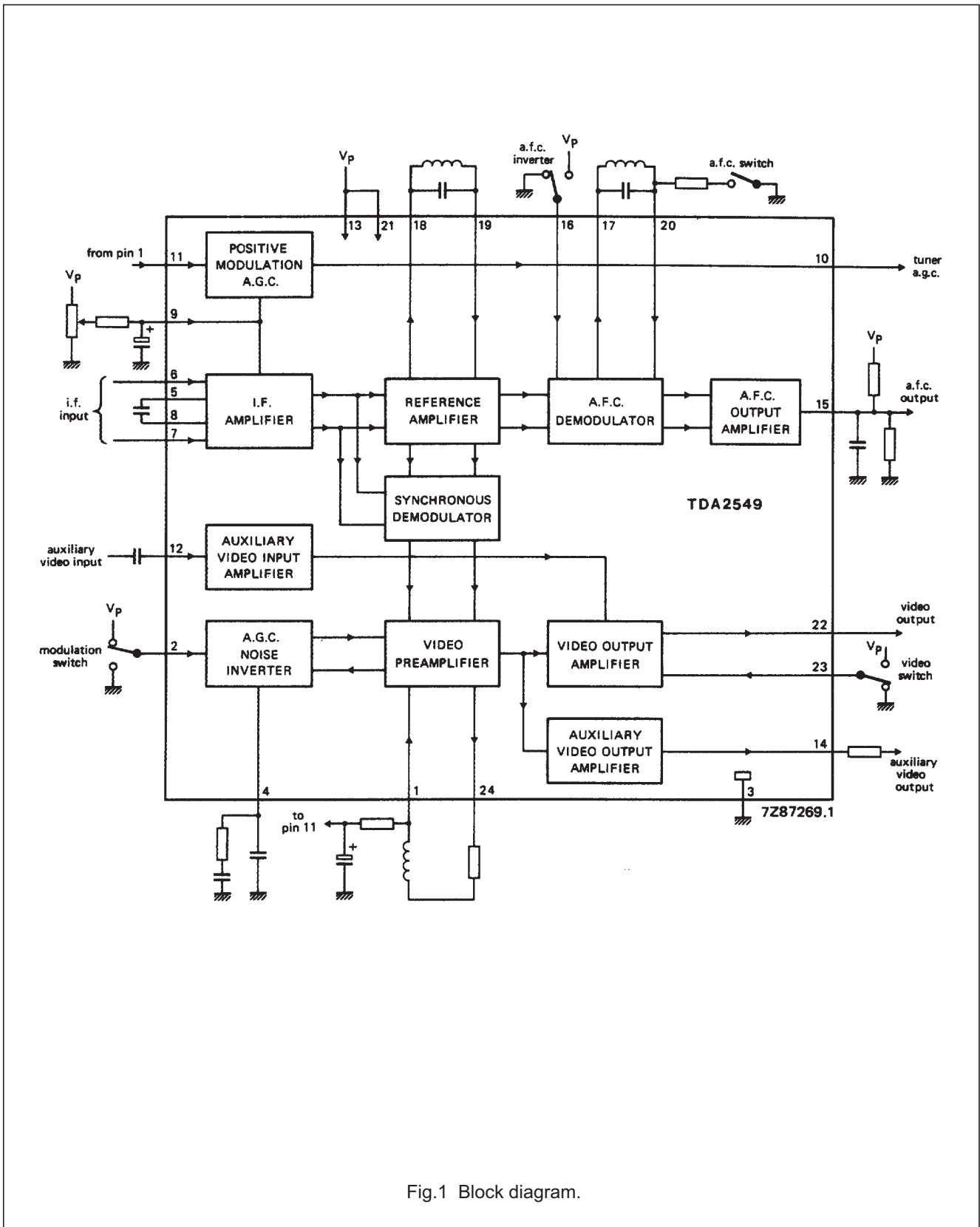

Fig.1 Block diagram.

# I.F. amplifier and demodulator for multistandard TV receivers

TDA2549

**RATINGS**

Limiting values in accordance with the Absolute Maximum System (IEC 134)

Supply voltage (pins 13 and 21)	$V_P$	13,8	V
Storage temperature range	$T_{stg}$	-25 to +125	°C
Operating ambient temperature range	$T_{amb}$	-25 to +70	°C

**CHARACTERISTICS** (measured in fig.5) $V_P = 12\text{ V}$ ;  $T_{amb} = 25\text{ °C}$ 

PARAMETER	SYMBOL	MIN.	TYP.	MAX.	UNIT
Supply voltage range	$V_P$	10,8	12	13,2	V
Supply current (pins 13 and 21)	$I_P$	–	82	–	mA
I.F. input signal for $V_o = 2\text{ V}$ (between pins 6 and 7)	$V_i = V_{6-7}$	–	50	150	$\mu\text{V}$
Input impedance (differential)	$ Z_{6-7} $	–	2	–	k $\Omega$
Input capacitance (differential)	$C_{6-7}$	–	2	–	pF
Zero single output level					
positive modulation	$V_{22-3}$	1,6	2	2,3	V
negative modulation	$V_{22-3}$	3,7	4	4,3	V
Top sync output level	$V_{22-3}$	1,7	2	2,3	V
Gain control range	$G_v$	50	74	–	dB
Signal-to-noise ratio at $V_i = 10\text{ mV}$ (note 1)	S/N	50	57	–	dB
Maximum video output amplitude for positive modulation (peak-to-peak value)	$V_{22-3(p-p)}$	4,5	–	–	V
Bandwidth of video amplifier (3 dB)	B	–	5,5	–	MHz
Differential gain at $V_o = 2\text{ V}$	dG	–	4	10	%
Differential phase at $V_o = 2\text{ V}$	d $\phi$	–	2	10	%
Residual carrier signal (r.m.s. value)	$V_{24-3(rms)}$	–	10	20	mV
Residual second harmonic of carrier signal (r.m.s. value)	$V_{24-3(rms)}$	–	20	60	mV

# I.F. amplifier and demodulator for multistandard TV receivers

## TDA2549

PARAMETER	SYMBOL	MIN.	TYP.	MAX.	UNIT
A.F.C. output voltage swing	$V_{15-3}$	10	–	–	V
Change of frequency required for a.f.c. output voltage swing of 10 V	$\Delta f$	–	70	200	kHz
A.F.C. switch off for a voltage lower than:	$V_{17-3}$	–	–	1,5	V
A.F.C. inverter switch					
positive a.f.c. (Fig.2)	$V_{16-3}$	0	–	1,5	V
negative a.f.c. (Fig.3)	$V_{16-3}$	4	–	12	V
<b>Tuner A.G.C.</b>					
Leakage current	$I_{10}$	–	–	15	$\mu A$
Saturation voltage					
$I_{10} = 0,3$ mA	$V_{10-3}$	–	0,1	0,3	V
take-over point LOW	$V_i$	–	–	3	mV
take-over point HIGH	$V_i$	10	–	–	mV
Signal expansion at $G_v = 50$ dB	$\Delta V_{22-3}$	–	–	0,5	dB
Negative modulation (Fig.4)					
white spot inverter threshold level	$V_{22-3}$	–	4,6	–	V
white spot insertion level	$V_{22-3}$	–	3,2	–	V
noise inverter threshold level	$V_{22-3}$	–	0,9	–	V
noise insertion level	$V_{22-3}$	–	2,5	–	V
Positive modulation a.g.c. detector					
reference level	$V_{11-3}$	3,0	3,2	3,4	V
Auxiliary video input signal for $V_{o(p-p)} = 2$ V	$V_{12-3}$	0,7	1	1,4	V
Auxiliary video output					
output signal (note 2)	$V_{14-3}$	–	1	–	V
top sync level	$V_{14-3}$	1	2	3	V
output impedance	$ Z_{14-3} $	–	7	–	$\Omega$
Levels for video switches					
positive video	$V_{2-3}$	–	–	1	V
negative video	$V_{2-3}$	3	–	–	V
internally demodulated signal	$V_{23-3}$	–	–	1	V
auxiliary video signal	$V_{23-3}$	3	–	–	V

### Notes to the characteristics

- Signal – to – noise ratio  $S/N = \frac{V_o \text{ black-to-white}}{V_{n(rms)}} \text{ at } B = 5 \text{ MHz}$
- Measured in application of Fig. 5.

I.F. amplifier and demodulator for multistandard TV receivers

TDA2549

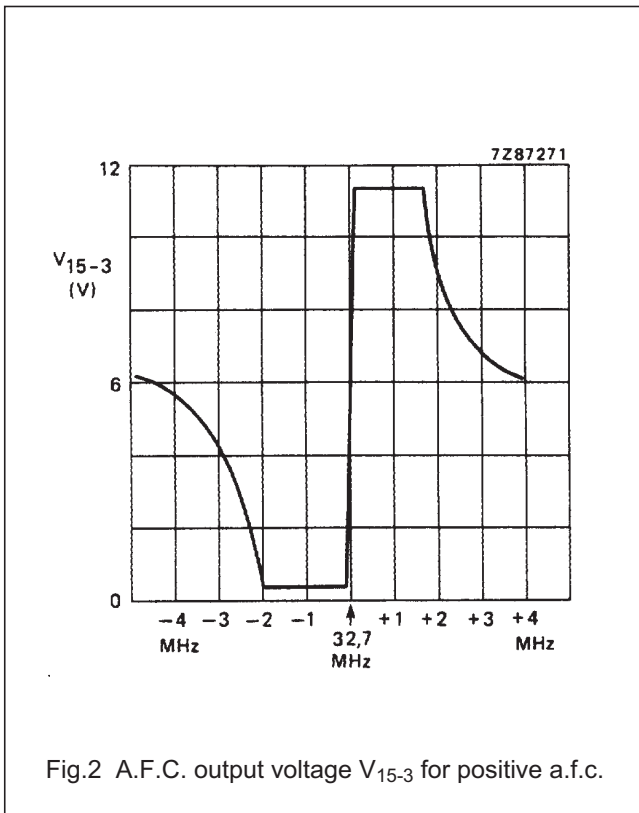

Fig.2 A.F.C. output voltage  $V_{15-3}$  for positive a.f.c.

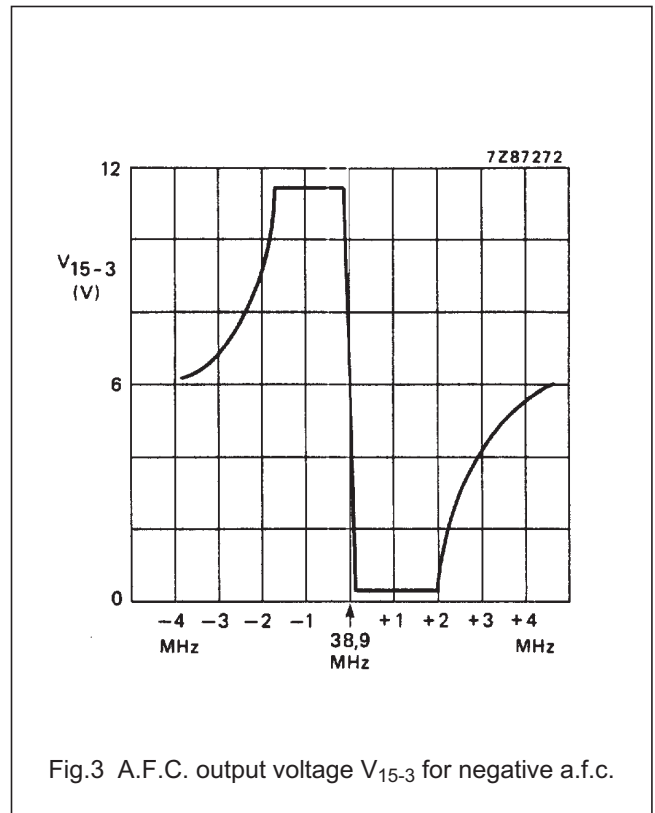

Fig.3 A.F.C. output voltage  $V_{15-3}$  for negative a.f.c.

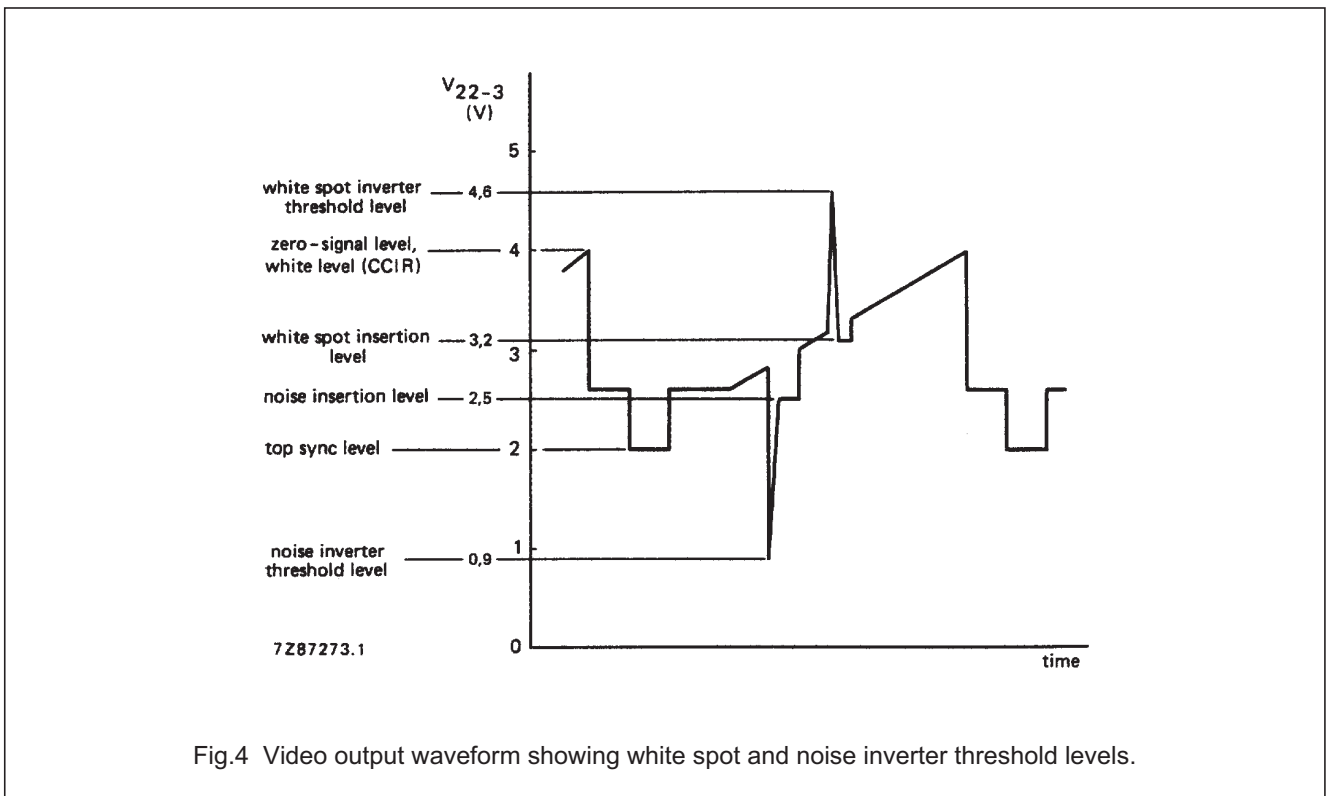

Fig.4 Video output waveform showing white spot and noise inverter threshold levels.

I.F. amplifier and demodulator for multistandard TV receivers

TDA2549

APPLICATION INFORMATION

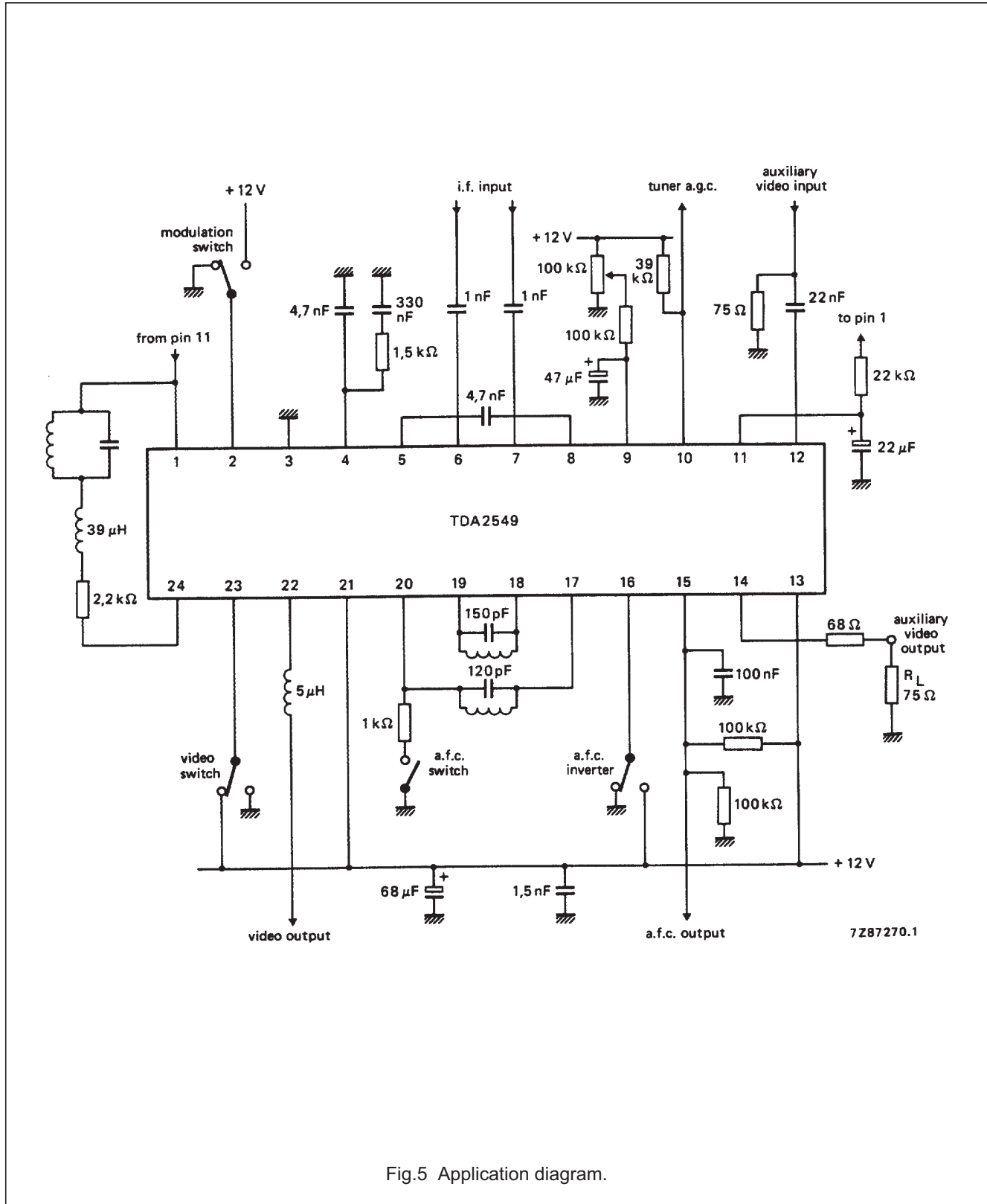

Fig.5 Application diagram.

I.F. amplifier and demodulator for multistandard TV receivers

TDA2549

PACKAGE OUTLINE

DIP24: plastic dual in-line package; 24 leads (600 mil)

SOT101-1

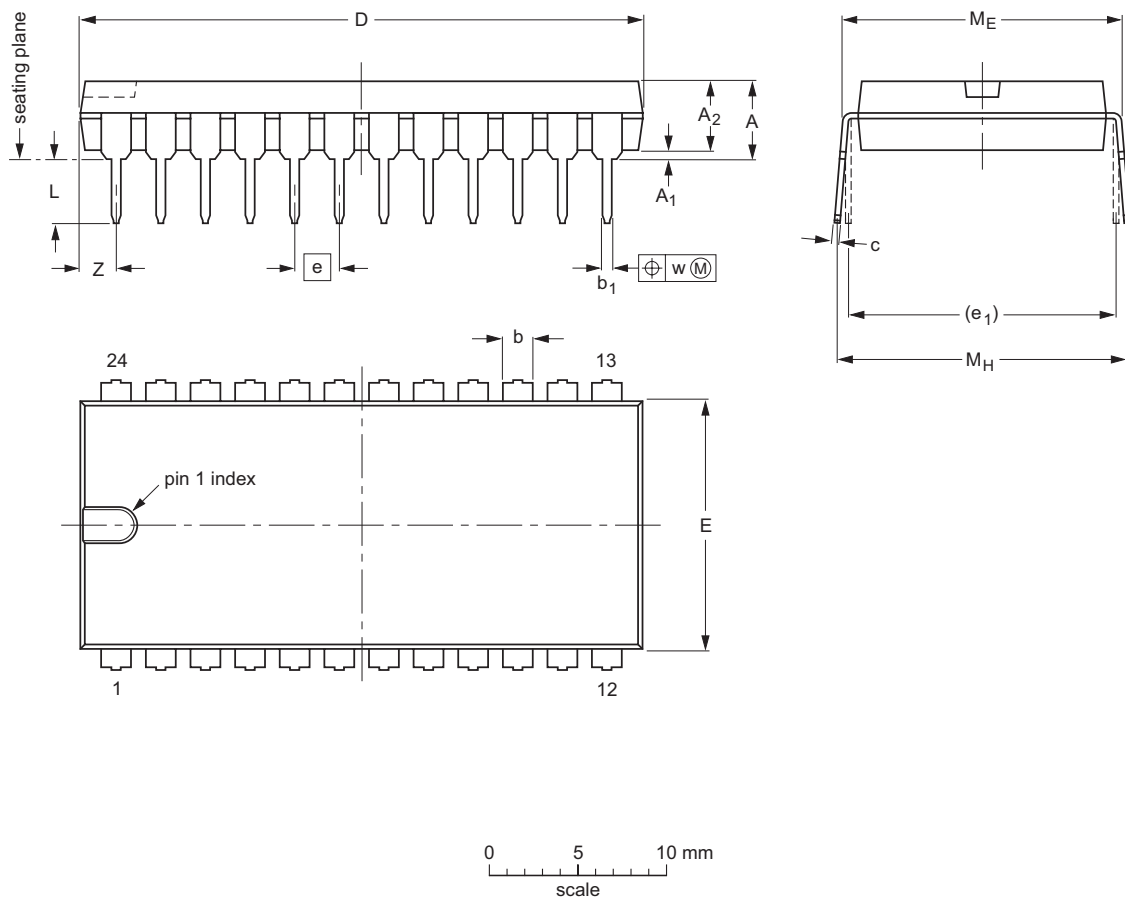

DIMENSIONS (inch dimensions are derived from the original mm dimensions)

UNIT	A max.	A <sub>1</sub> min.	A <sub>2</sub> max.	b	b <sub>1</sub>	c	D <sup>(1)</sup>	E <sup>(1)</sup>	e	e <sub>1</sub>	L	M <sub>E</sub>	M <sub>H</sub>	w	Z <sup>(1)</sup> max.
mm	5.1	0.51	4.0	1.7 1.3	0.53 0.38	0.32 0.23	32.0 31.4	14.1 13.7	2.54	15.24	3.9 3.4	15.80 15.24	17.15 15.90	0.25	2.2
inches	0.20	0.020	0.16	0.066 0.051	0.021 0.015	0.013 0.009	1.26 1.24	0.56 0.54	0.10	0.60	0.15 0.13	0.62 0.60	0.68 0.63	0.01	0.087

Note

1. Plastic or metal protrusions of 0.25 mm maximum per side are not included.

OUTLINE VERSION	REFERENCES				EUROPEAN PROJECTION	ISSUE DATE
	IEC	JEDEC	EIAJ			
SOT101-1	051G02	MO-015AD				92-11-17 95-01-23



## I.F. amplifier and demodulator for multistandard TV receivers

TDA2549

### SOLDERING

#### Introduction

There is no soldering method that is ideal for all IC packages. Wave soldering is often preferred when through-hole and surface mounted components are mixed on one printed-circuit board. However, wave soldering is not always suitable for surface mounted ICs, or for printed-circuits with high population densities. In these situations reflow soldering is often used.

This text gives a very brief insight to a complex technology. A more in-depth account of soldering ICs can be found in our "IC Package Databook" (order code 9398 652 90011).

#### Soldering by dipping or by wave

The maximum permissible temperature of the solder is 260 °C; solder at this temperature must not be in contact with the joint for more than 5 seconds. The total contact time of successive solder waves must not exceed 5 seconds.

The device may be mounted up to the seating plane, but the temperature of the plastic body must not exceed the specified maximum storage temperature ( $T_{stg\ max}$ ). If the printed-circuit board has been pre-heated, forced cooling may be necessary immediately after soldering to keep the temperature within the permissible limit.

#### Repairing soldered joints

Apply a low voltage soldering iron (less than 24 V) to the lead(s) of the package, below the seating plane or not more than 2 mm above it. If the temperature of the soldering iron bit is less than 300 °C it may remain in contact for up to 10 seconds. If the bit temperature is between 300 and 400 °C, contact may be up to 5 seconds.

### DEFINITIONS

Data sheet status	
Objective specification	This data sheet contains target or goal specifications for product development.
Preliminary specification	This data sheet contains preliminary data; supplementary data may be published later.
Product specification	This data sheet contains final product specifications.
Limiting values	
Limiting values given are in accordance with the Absolute Maximum Rating System (IEC 134). Stress above one or more of the limiting values may cause permanent damage to the device. These are stress ratings only and operation of the device at these or at any other conditions above those given in the Characteristics sections of the specification is not implied. Exposure to limiting values for extended periods may affect device reliability.	
Application information	
Where application information is given, it is advisory and does not form part of the specification.	

### LIFE SUPPORT APPLICATIONS

These products are not designed for use in life support appliances, devices, or systems where malfunction of these products can reasonably be expected to result in personal injury. Philips customers using or selling these products for use in such applications do so at their own risk and agree to fully indemnify Philips for any damages resulting from such improper use or sale.