

SANYO

No.2767A

LA7295 Series

VTR Audio Signal Recording / Playback Processor

Features

- Single-chip ICs that provide various functions (including two tape head select switches, a power supply switch for the OSC bias circuit, and five equalizer select switches (LP, EP) required for VTR audio signal recording / playback)
- High merit in space because of SIP package
- Minimum number of external parts required

LA7295	· · · V _{CC} = 12V, PB "Hi"
LA7294	· · · V _{CC} = 12V, PB "Hi", no EE muting function
LA7296	· · · V _{CC} = 12V, PB "Lo"
LA7297	· · · V _{CC} = 9V, PB "Hi"

Block Diagram

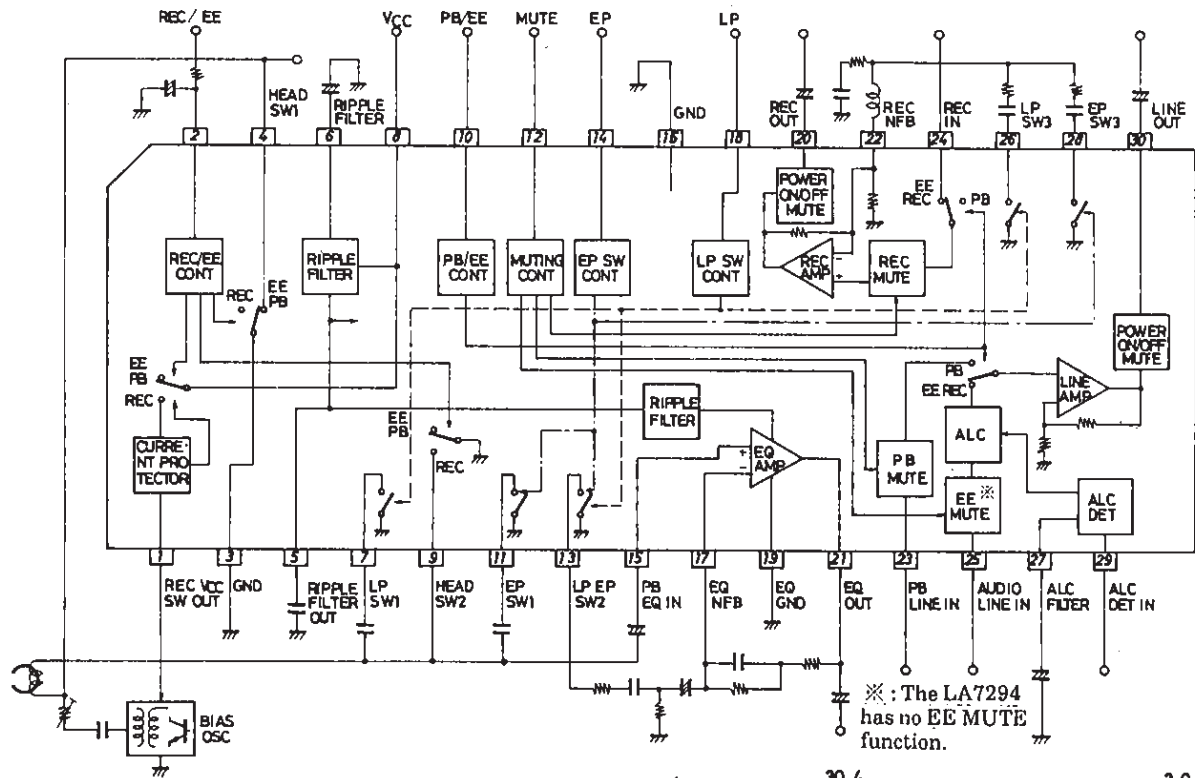

Package Dimensions 3117 (unit:mm)

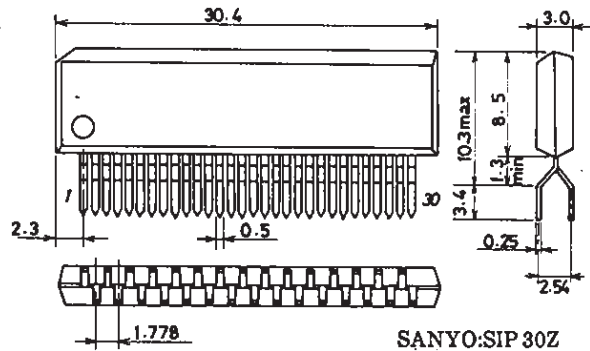

SANYO Electric Co., Ltd. Semiconductor Business Headquarters
 TOKYO OFFICE Tokyo Bldg., 1-10, 1 Chome, Ueno, Taito-ku, TOKYO, 110 JAPAN

LA7294,7295,7296,7297

Maximum Ratings at Ta = 25°C		LA7294/95/96	LA7297	unit
Maximum Supply Voltage	V _{CC} max	14	11	V
Allowable Power Dissipation	P _d max Ta = 65°C	600	600	mW
Operating Temperature	T _{opr}	-10 to +65	-10 to +65	°C
Storage Temperature	T _{stg}	-55 to +125	-55 to +125	°C

Operating Conditions at Ta = 25°C		LA7294/95/96	LA7297	unit
Recommended Supply Voltage	V _{CC}	12.0	9.0	V
Operating Voltage Range	V _{CC} op	11.25 to 12.75	8.25 to 9.75	V

Operating Characteristics at Ta = 25°C, V_{CC} = 12V(9V), f = 1kHz, 0dBv:1.0Vrms

			min	typ	max	unit
Current Dissipation (EE)	I _{CCE} Quiescent		11.0	15.0	20.0	mA
Current Dissipation (PB)	I _{CCP} Quiescent		12.0	16.0	21.0	mA
Current Dissipation (REC)	I _{CCR} Quiescent		9.0	13.0	18.0	mA
Overall Gain at PB Mode	V _G PB EQ IN to LINE OUT, V _o = -5dBv		67.0	68.0	69.0	dB
[Equalizer Amp]						
Open-Loop Voltage Gain	V _G OE V _o = -5dBv		67.0	72.0		dB
Equivalent Input Noise Voltage	V _{NIE} R _g = 2.2kΩ, DIN audio filter			1.0	1.8	μVrms
Input Resistance	r _{ie}			130		kΩ
[Line Amp]						
Voltage Gain (PB Input)	V _G L _P V _o = -5dBv		32.0	33.0	34.0	dB
Voltage Gain (EE, REC Input)	V _G L _R V _o = -5dBv		32.0	33.0	34.0	dB
Total Harmonic Distortion	THD _L V _o = -5dBv			0.15	0.40	%
Output Noise Voltage	V _{NOL} DIN audio filter *			-70.0	-64.0	dBv
Input Resistance (PB Input)	r _{i1}			30.0		kΩ
Input Resistance (EE, REC Input)	r _{i2}			30.0		kΩ
Maximum Output Voltage	V _{OML} THD = 1%		1.5	2.2		Vrms
Output Voltage at ALC Mode	V _{OA} V _{IN} = -35dBv		-6.5	-5.0	-3.5	dBv
ALC Effect	ALC V _{IN} = -35 to -10dBv			1.0	3.0	dB
Total Harmonic Distortion at ALC Mode	THD _A V _{IN} = -35dBv			0.2	0.6	%
[Recording Amp]						
Voltage Gain (Open Loop)	V _G OR V _o = -5dBv		51.0	57.0		dB
Voltage Gain (Closed Loop)	V _G CR V _o = -5dBv		13.5	14.5	15.5	dB
Total Harmonic Distortion	THD _R V _o = -5dBv			0.1	0.3	%
Input Resistance	r _{ir}			30.0		kΩ
Maximum Output Voltage	V _{OMR} THD = 1%		1.5	2.2		Vrms
[Muting Circuit]						
ON-State Voltage	V _{MON} Pin 12 DC		3.3		V _{CC}	V
OFF-State Voltage	V _{MOFF} Pin 12 DC		0		1.0	V
Muting Attenuation (PB, EE)	M _P , M _E LA7294: No EE required		85.0	90.0		dB
Muting Attenuation (REC)	M _R		73.0	78.0		dB
[PB/EE Select Circuit]						
PB Mode Hold Voltage (LA7296 EE mode)	V _{PP} Pin 10 DC		3.3		6.0	V
EE Mode Hold Voltage (LA7296 PB mode)	V _{PE} Pin 10 DC		0		1.0	V
[REC/EE Select Circuit]						
REC Mode Hold Voltage	V _{RR} Pin 2 DC		3.8		6.0	V
EE Mode Hold Voltage	V _{RE} Pin 2 DC		0		1.0	V

Continued on next page.

LA7294,7295,7296,7297

Continued from preceding page.

			min	typ	max	unit
[Equalizer Select Circuit]						
Switch ON-State Voltage	V_{EON}	Pins 14,18 DC	3.0		6.0	V
Switch OFF-State Voltage	V_{EOFF}	Pins 14,18 DC	0		0.8	V
[Head Select Switch]						
Pin 4 ON-State Resistance	R_{ON4}	$I_4 = \pm 1\text{mA}$		10	20	Ω
Pin 9 ON-State Resistance	R_{ON9}	$I_9 = \pm 1\text{mA}$		5	10	Ω
Pin 4 Input Voltage	V_{IN4}	$T_a = 65^\circ\text{C}, f = 80\text{kHz}(\text{sin})$ $I_{LK} = 10\mu\text{A}$			± 40	V
[REC V_{CC} Switch]						
Pin 1 Output Voltage (LA7294/95/96)	V_{RO}	Pin 1 load current 100mA	10.5	10.8		V
Pin 1 Output Voltage (LA7297)	V_{RO}	Pin 1 load current 100mA	7.5	7.8		V

Test Circuit

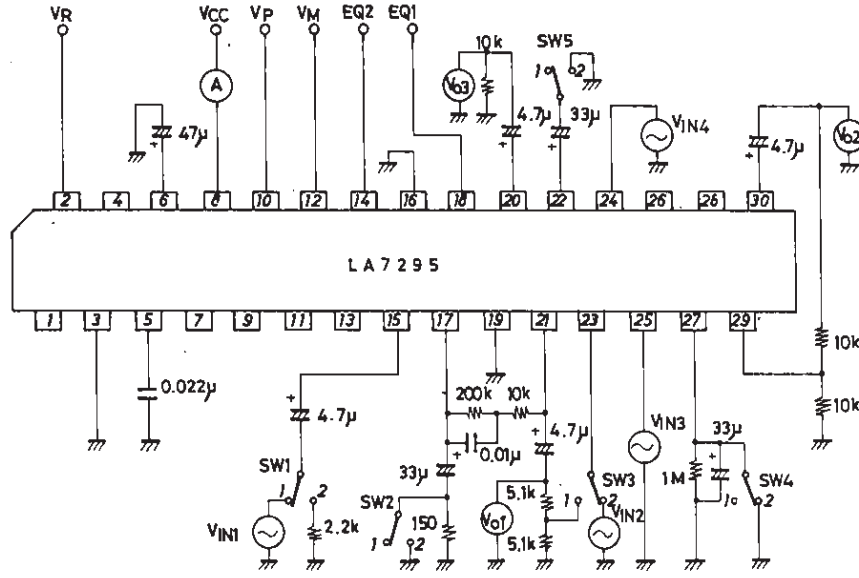

Unit (resistance: Ω, capacitance: F)

(Switch Operating Table)

Item (Symbol)	SW1	SW2	SW3	SW4	SW5	V _M	V _P	V _R	Input	Test
I _{CCE}	2	1	1	2	1	GND	GND	GND		A
I _{CCP}	2	1	1	2	1	GND	5V	GND		A
I _{CCR}	2	1	1	2	1	GND	GND	5V		A
V _{G_{PB}}	1	1	1	2	1	GND	5V	GND	V _{IN1}	Vo2
V _{G_{OE}}	1	2	2	2	1	GND	5V	GND	V _{IN1}	Vo1
V _{NIE}	2	1	2	2	1	GND	5V	GND		Vo1
V _{G_{LP}} , THD _L , V _{OML}	2	1	2	2	1	GND	5V	GND	V _{IN2}	Vo2
V _{G_{LR}}	2	1	1	2	1	GND	GND	GND	V _{IN3}	Vo2
V _{NOL}	2	1	2	2	1	GND	GND	GND		Vo2
V _{OΔ} , ALC, THD _Δ	2	1	2	1	1	GND	GND	GND	V _{IN3}	Vo2
V _{G_{OR}}	2	1	2	2	2	GND	GND	GND	V _{IN4}	Vo3
V _{G_{CR}} , THD _R , V _{OMR}	2	1	2	2	1	GND	GND	GND	V _{IN4}	Vo3
M _P	1	1	1	2	1	5V	5V	GND	V _{IN1}	Vo2
M _R	2	1	1	2	1	5V	GND	GND	V _{IN4}	Vo3
M _E	2	1	2	2	1	5V	GND	GND	V _{IN2}	Vo2

For the LA7294 that has no EE MUTE function, the ME test is not required.

ALC Output Level Setting

The ALC output level depends on the value of the resistor connected to the detector input (pin 29) as shown below.

ALC Operation Start Output Level vs. ALC Input Resistance

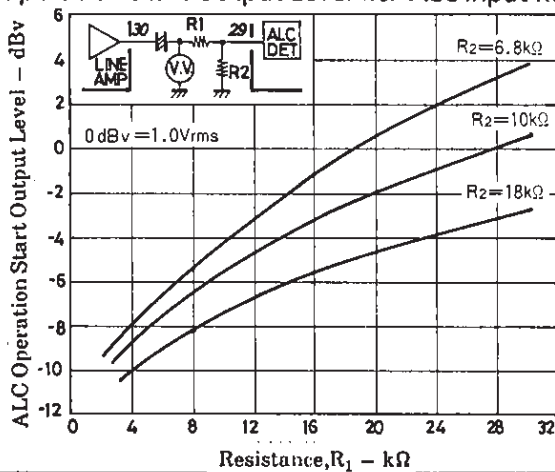

Sample Application Circuit

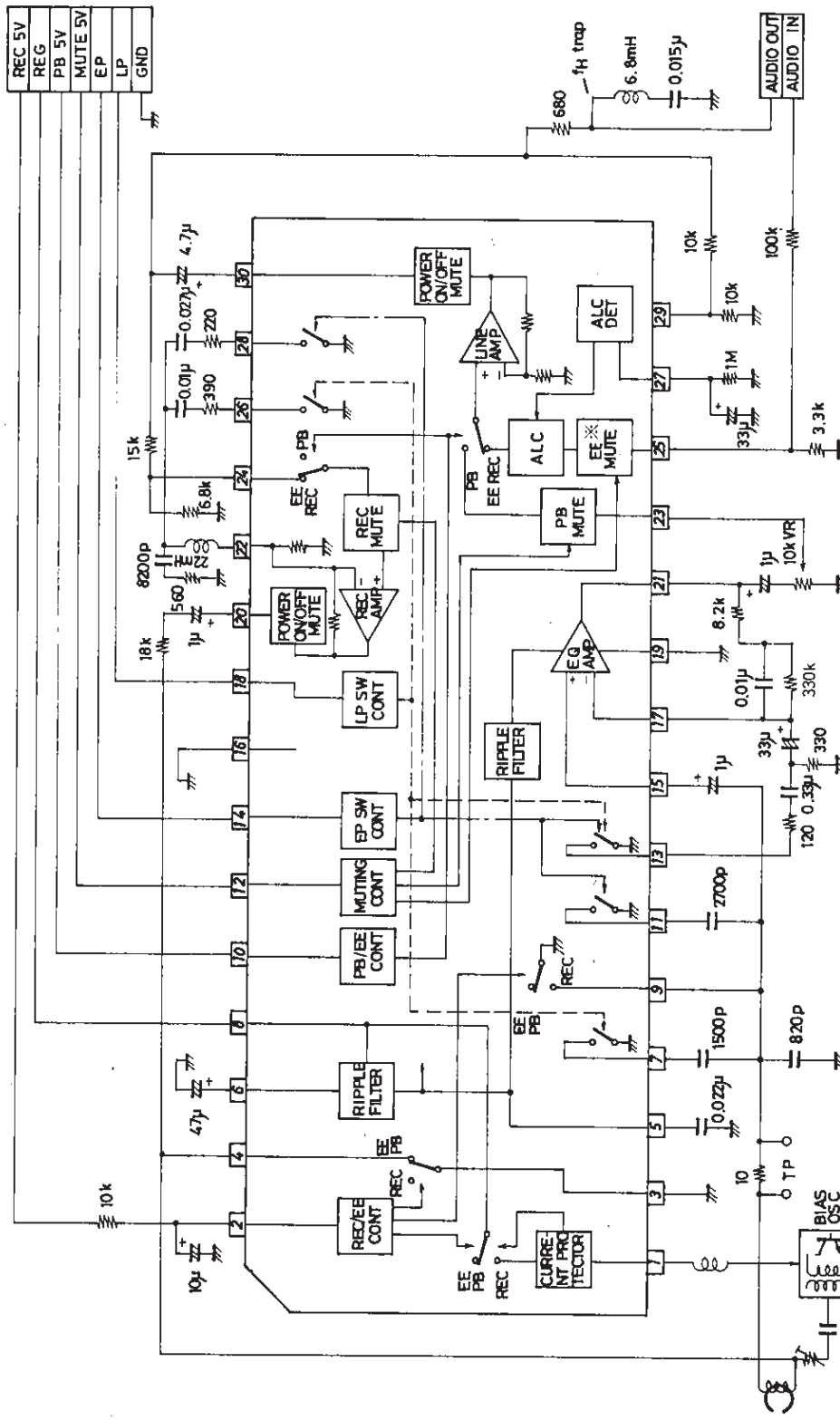

※ : The LA7294 has no EE MUTE function.

Unit (resistance: Ω, capacitance: F)

- No products described or contained herein are intended for use in surgical implants, life-support systems, aerospace equipment, nuclear power control systems, vehicles, disaster/crime-prevention equipment and the like, the failure of which may directly or indirectly cause injury, death or property loss.
- Anyone purchasing any products described or contained herein for an above-mentioned use shall:
 - ① Accept full responsibility and indemnify and defend SANYO ELECTRIC CO., LTD., its affiliates, subsidiaries and distributors and all their officers and employees, jointly and severally, against any and all claims and litigation and all damages, cost and expenses associated with such use:
 - ② Not impose any responsibility for any fault or negligence which may be cited in any such claim or litigation on SANYO ELECTRIC CO., LTD., its affiliates, subsidiaries and distributors or any of their officers and employees jointly or severally.
- Information (including circuit diagrams and circuit parameters) herein is for example only; it is not guaranteed for volume production. SANYO believes information herein is accurate and reliable, but no guarantees are made or implied regarding its use or any infringements of intellectual property rights or other rights of third parties.