

BA5410

12 V-5.2 W dual channel power amplifier

The BA5410 is a dual channel, power amplifier designed for stereo radio cassette players.

Features

- available in HSIP10 package
- wide operating voltage range, typically 6 ~ 14 V
- power amplifier has high output (2.9 W \times 2 at $R_L = 3 \Omega$, $V_{CC} = 9 V$, THD = 10%), low noise (0.3 mV_{rms}) and low distortion (0.3%)
- power output increases to 5.2 W \times 2 at $R_L = 3 \Omega$, $V_{CC} = 12 V$, THD = 10%
- good channel balance
- good distortion factor (THD = 0.3% at $P_O = 0.5 W$)
- built-in power switching and thermal shutdown circuit

Applications

- stereo radio-cassette tape player

Dimensions (Units : mm)

BA5410 (HSIP10)

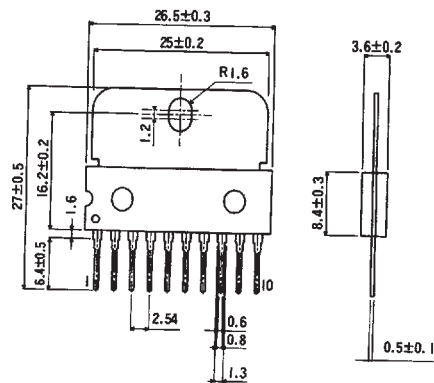
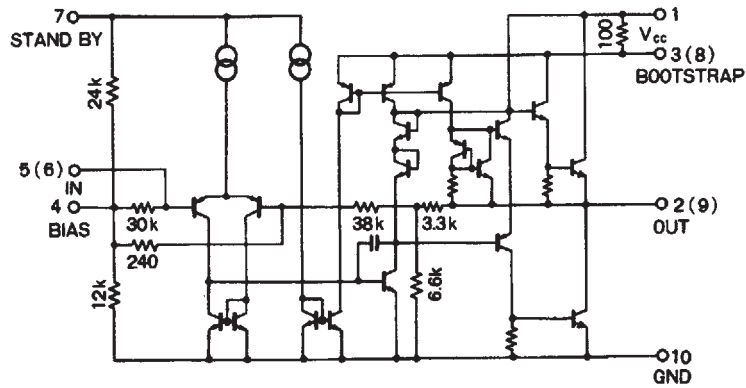

Figure 1 Equivalent circuit diagram

Absolute maximum ratings ($T_a = 25^\circ\text{C}$)

Parameter	Symbol	Limits	Unit	Conditions
Power supply voltage	V_{CC}	20	V	
Power dissipation	P_d	12.5	W	With a heat sink operating temperature less than 75°C . See Figure 13
Operating temperature	T_{opr}	$-25 \sim +75$	$^\circ\text{C}$	
Storage temperature	T_{stg}	$-55 \sim +125$	$^\circ\text{C}$	

Recommended operating conditions ($T_a = 25^\circ\text{C}$)

Parameter	Symbol	Min	Typical	Max	Unit
Power supply voltage	V_{CC}	6		14	V

Electrical characteristics (Unless otherwise noted $T_a = 25^\circ\text{C}$, $V_{CC} = 9\text{ V}$, $f = 1\text{ kHz}$, $R_L = 3\ \Omega$, $f = \text{kHz}$)

Parameter	Symbol	Min	Typical	Max	Unit	Conditions
Quiescent current	I_Q	17	25	41	mA	
Voltage gain (close circuit)	G_{VC}	45.5	47.5	49.5	dB	$P_O = 0.5\text{ W}$
Rated output 1	P_{OUT1}	2.5	2.9		W	THD = 10%
Rated output 2	P_{OUT2}		5.2		W	THD = 10%, $V_{CC} = 12\text{ V}$
Total harmonic distortion	THD		0.3	1	%	$P_O = 0.5\text{ W}$
Output noise voltage	V_{NO}		0.3	1	mV_{rms}	$R_g = 0\ \Omega$, BPF = 20 Hz ~ 20 kHz
Input resistance	R_{IN}	25	33	41	$\text{k}\Omega$	$P_O = 0.5\text{ W}$
Crosstalk	CT	40	50		dB	$R_g = 10\ \text{k}\Omega$, $P_O = 0.5\text{ W}$
Ripple rejection	RR	40	45		dB	$V_{RR} = -20\text{ dBV}$, $f = 100\text{ Hz}$, $R_g = 0\ \Omega$

BA5410 Power amplifiers

Figure 2 Test circuit

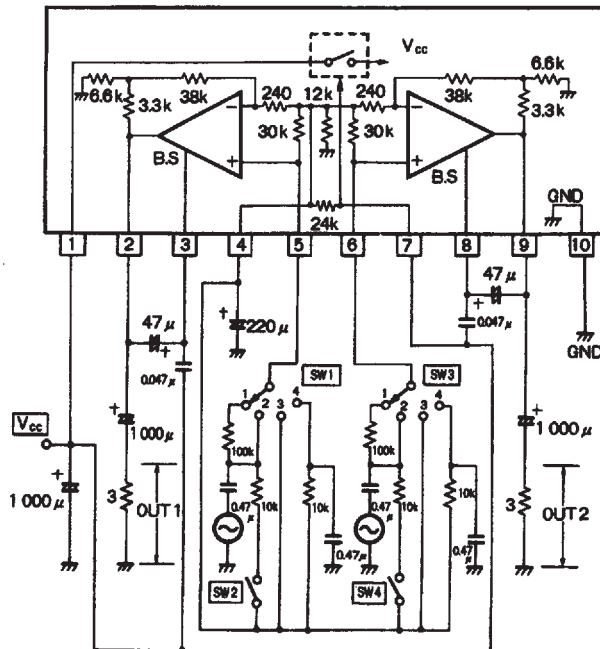
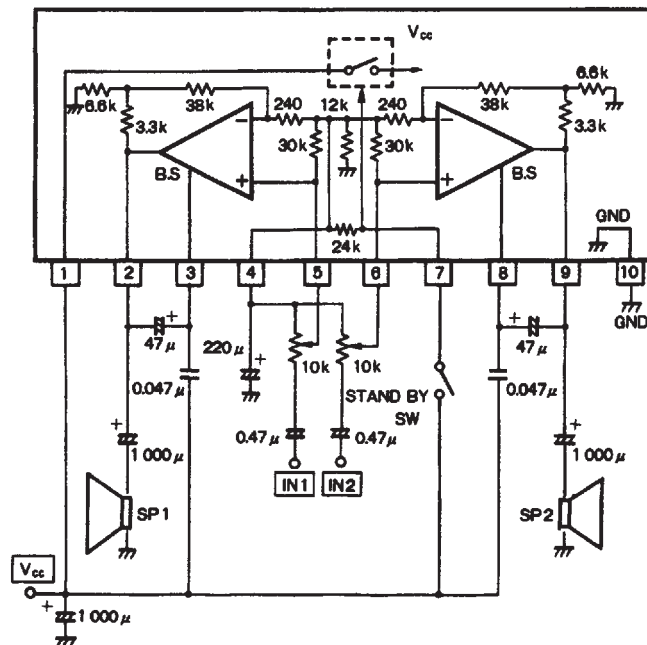

Figure 3 Application example



Precautions for use

Start up mute time

The start up mute time is determined by the capacitor on pin 4. Set a mute time that matches the preamplifier and the power supply voltage used.

Polarity of the input capacitor

Ensure that the polarity of the input capacitor is matched to the dc output voltage of the preamplifier that you are using. The dc voltage of the input pin is set to approximately $V_{CC}/3$. This ratio will change on power up and power down.

Input volume

Connect the input volume control between the input and the bias as in the application circuit diagram. The potentiometer should have a maximum resistance of 10 k Ω or less. Since this is a dc amplifier, this prevents the output operating point from shifting due to the input offset current.

Bootstrap

Stability of the amplifier is maintained by connecting the bootstrap capacitor (0.47 μ F) and the anti-oscillation capacitor (0.047 μ F). If the dc resistance of the bootstrap capacitor is too small, the amplifier may become unstable. In this case, connect a 3 Ω resistor in series with the 0.047 μ F capacitor.

Standby state

When the power supply is OFF, if a large noise is present on the standby pin (pin 7), it may leak to the output. Prevent this by connecting a capacitor in parallel to the noise generation source.

Electrical characteristic curves

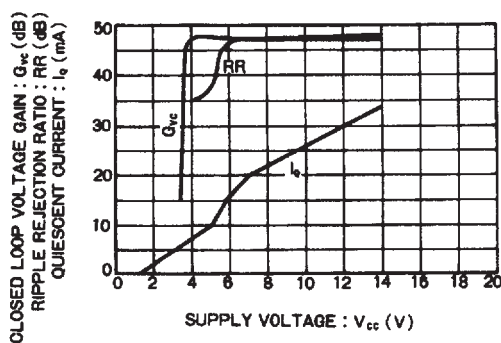

Figure 4

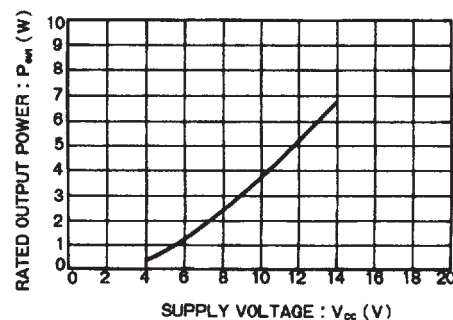

Figure 5

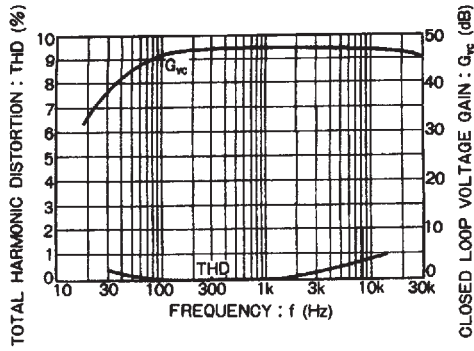

Figure 6

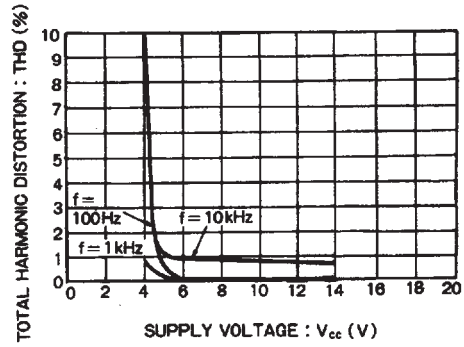

Figure 7

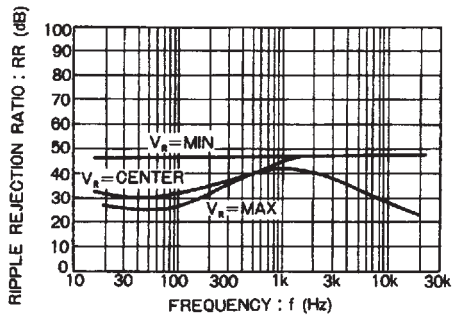

Figure 8

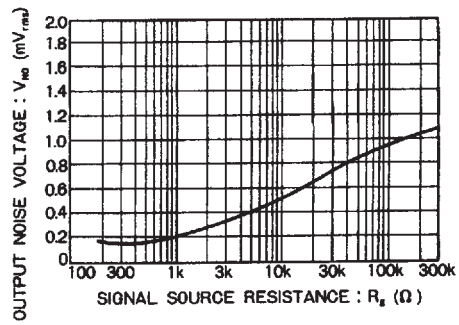

Figure 9

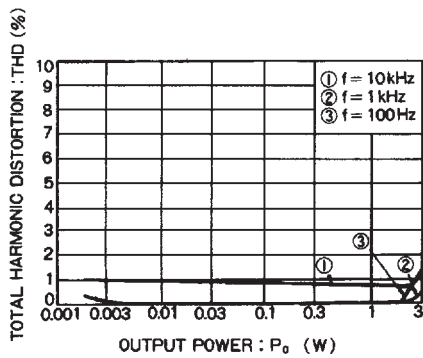

Figure 10

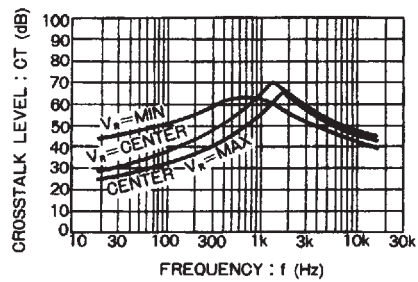

Figure 11

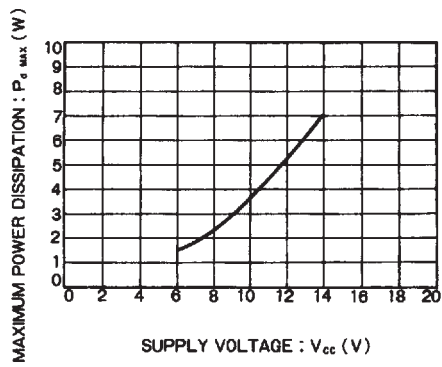

Figure 12

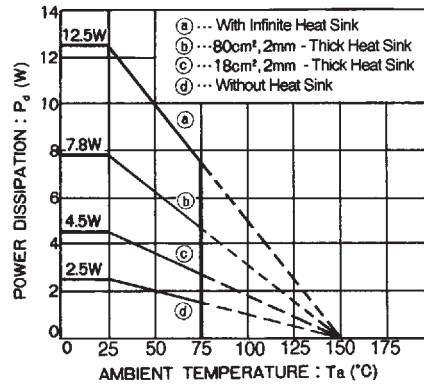

Figure 13