

Dimensions (mm)

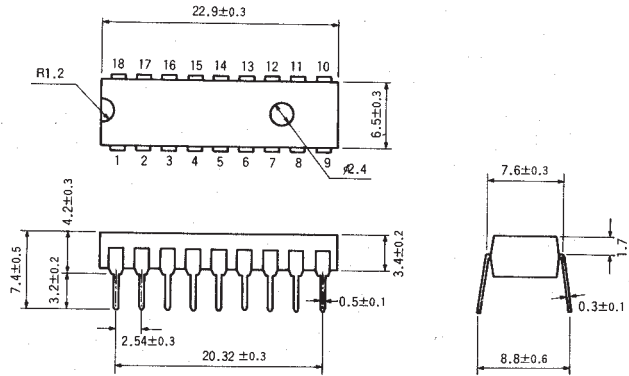

Fig. 1

The BA5102A is a monolithic integrated circuit designed to simplify VTR audio signal circuitry. It includes in a single chip the record/playback preamplifier, line amplifier, recording amplifier, ALC circuit, recording/playback/muting control circuit, and analog switch normally found in conventional systems.

Logic control is used, so that by merely setting the recording/playback control pin voltage, the amplifier and signal paths are automatically switched between recording and playback and the muting functions are appropriately controlled. Therefore, whereas conventional systems have required switches (relays) and complex wiring, a system using this device can be implemented with a relatively simple PC board, enabling a significant savings in space. In addition, improvements in reliability have been achieved.

**Features**

1. All the required audio signal system recording/playback amplifiers for a VTR system have been included in this single package.
2. Setting of recording/playback and muting modes is controlled by changing the voltage on a control pin.
3. Shock noise accompanying mode switching has been drastically reduced.
4. Simple recording level and playback sensitivity adjustment is possible.
5. Improved reliability with electronic switching

**Applications**

1. 9 and 12V VTR audio system units
2. Logic-controlled tape recorders

**Block Diagram**

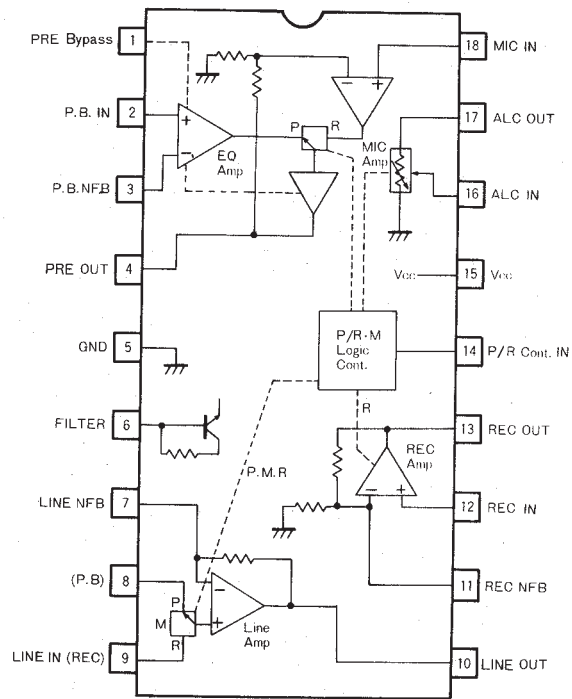

Fig. 2

**Absolute Maximum Ratings (T<sub>a</sub> = 25° C)**

Parameter	Symbol	Limits	Unit
Supply voltage	V <sub>CC</sub>	15	V
Power dissipation	P <sub>d</sub>	700	mW
Operating temperature	T <sub>opr</sub>	-10~+65	°C
Storage temperature	T <sub>stg</sub>	-55~+125	°C

Electrical Characteristics ( $T_a = 25^\circ\text{C}$ ,  $V_{CC} = 9\text{V}$ ,  $f = 1\text{kHz}$ )

Parameter	Symbol	Limits				Unit	Conditions	Test circuit
		EQ Amp	MIC Amp	LINE Amp	REC Amp			
Voltage gain	$G_{VC}$	44	37.5	35(playback)/30(record)	13( $G_{VO} = 42$ )	dB	$V_{OUT} = 0\text{dBm}$	Fig. 3
Output voltage	$V_{om}$	2.2	2.2	2.4	2.3	V	THD = 3%	Fig. 3
Total harmonic distortion	THD	0.1	0.07	0.3	0.2	%	$V_{OUT} = 0\text{dBm}$	Fig. 3
Input resistance	$R_{IN}$	55	55	—	—	$k\Omega$		Fig. 3
Input referred noise voltage	$V_{NIN}$	1	1	—	—	$\mu\text{V}$	$R_g = 2.2k\Omega$ (DIN AUDIO)	Fig. 3
Supply current (playback)	$I_{CC} (P)$	8.5				mA		Fig. 3
Supply current (record)	$I_{CC} (B)$	10				mA		Fig. 3

Test Circuit

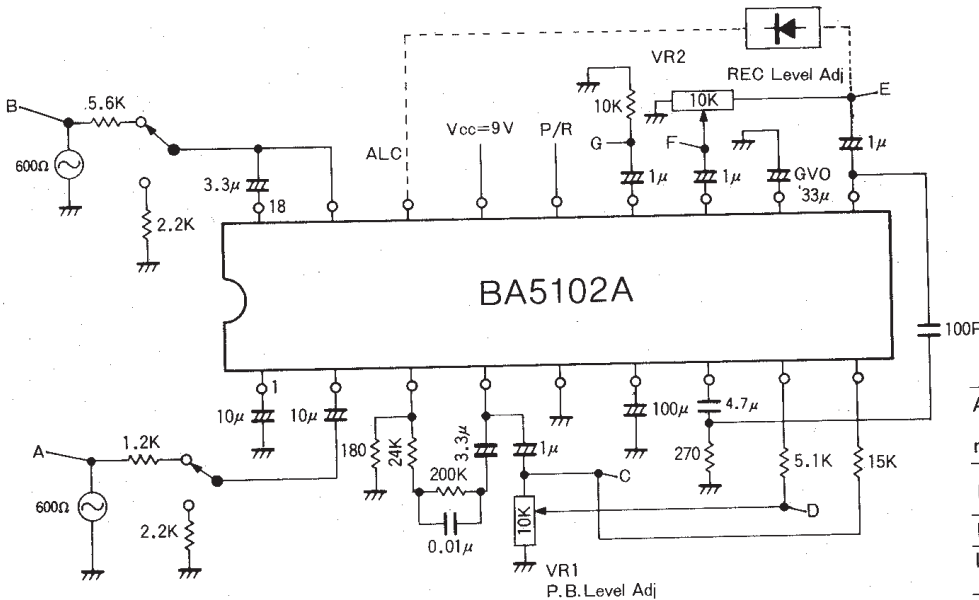

Fig. 3

Amplifier being measured	Measurement points	P/R Terminal voltage
EQ Amp	A~C	$V_{CC}$ (playback)
MIC Amp	B~C	GND (record)
Line amp (playback)	D~E	$V_{CC}$ (playback)
Line amp (record)	C~E	GND (record)
REC Amp	F~G	GND (record)

\* Original mode is held.

Electrical Characteristic Curves

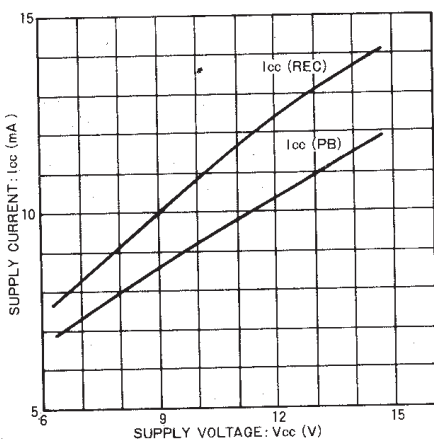

Fig. 4 Supply current vs. supply voltage

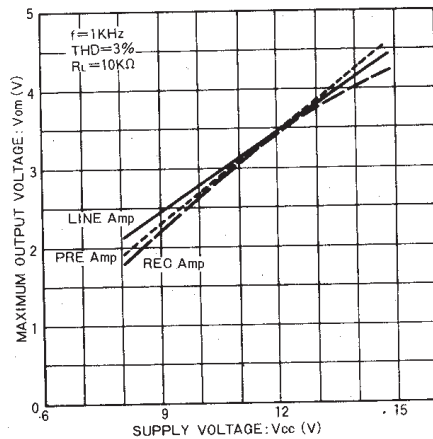

Fig. 5 Maximum output voltage vs. supply voltage

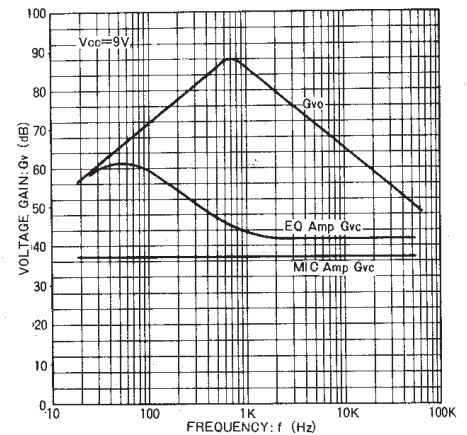

Fig. 6 Preamplifier voltage gain vs. frequency