

# 6V/430mW single-channel power amplifier

## BA526

The BA526 is a high-output monolithic power amplifier with excellent audio quality. With a 6V power supply, it has a rated output of 430mW into an 8  $\Omega$  load (THD = 10%), and a maximum output of 700mW. It comes in a compact 9-pin SIP package.

### ● Applications

Portable radios,  
TV sets,  
cassette recorders,  
interphones,  
and wireless tranceivers

### ● Features

- 1) High output.  $P_{OUT} = 430\text{mW}$  ( $V_{CC} = 6\text{V}$  and an 8  $\Omega$  load (THD = 10%).
- 2) Good low voltage characteristics. Begins operating at 2V.
- 3) Easy-to-mount 9-pin SIP package.
- 4) Extremely low high-frequency distortion with small signals. Uses soft clipping for good audio quality.
- 5) Power-on "pop" noise is suppressed.
- 6) Low noise.

### ● Block diagram

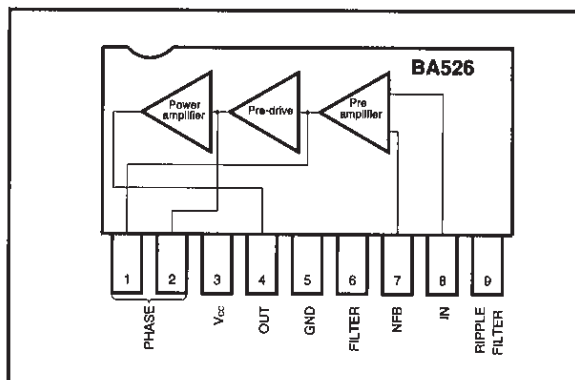

● Internal circuit diagram

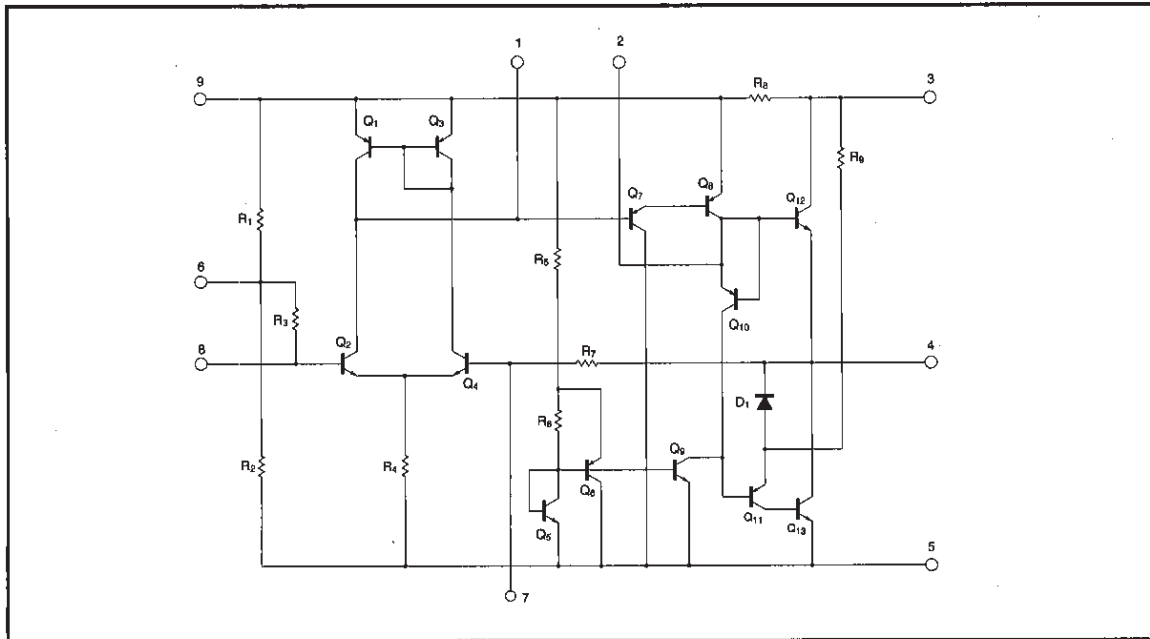

● Absolute maximum ratings (Ta = 25°C)

Parameter	Symbol	Limits	Unit
Supply voltage	V <sub>CC</sub>	9	V
Power dissipation	P <sub>d</sub>	950*	mW
Operating temperature	T <sub>opr</sub>	-10~65	°C
Storage temperature	T <sub>stg</sub>	-30~125	°C

\* Reduced by 9.5mW for each increase in Ta of 1°C over 25°C.

● Electrical characteristics (unless otherwise specified Ta = 25°C, V<sub>CC</sub> = 6V, R<sub>L</sub> = 8 Ω and f = 1kHz)

Parameter	Symbol	Min.	Typ.	Max.	Unit	Condition	Measurement Circuit
Quiescent circuit current	I <sub>Q</sub>	—	12	24	mA	V <sub>IN</sub> =0V <sub>rms</sub>	Fig.1
Closed-circuit voltage gain	G <sub>VC</sub>	48	52	54	dB	R <sub>NF</sub> =47 Ω, V <sub>IN</sub> =2.5mV <sub>rms</sub>	Fig.1
Maximum output power	P <sub>OM</sub>	600	700	—	mW	V <sub>IN</sub> =25mV <sub>rms</sub>	Fig.1
Rated output power	P <sub>OUT</sub>	350	430	—	mW	THD=10%	Fig.1
Output noise voltage	V <sub>NO</sub>	—	0.25	0.7	mV <sub>rms</sub>	R <sub>g</sub> =0 Ω	Fig.1
Total harmonic distortion	THD	—	0.4	2	%	P <sub>O</sub> =50mW	Fig.1
Input resistance	R <sub>IN</sub>	—	22	—	kΩ	P <sub>O</sub> =50mW	Fig.1

● Measurement circuit

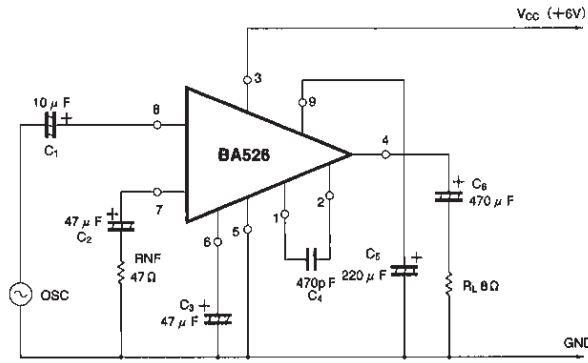

Fig. 1

● Application example

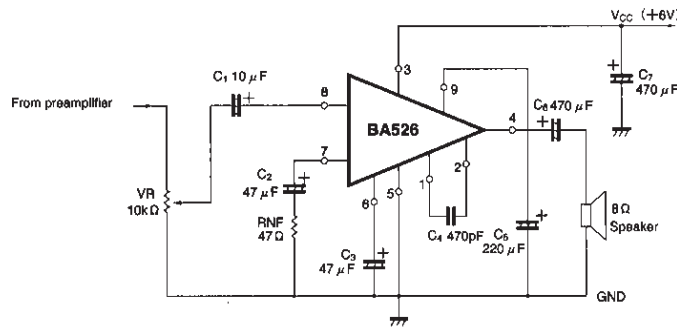
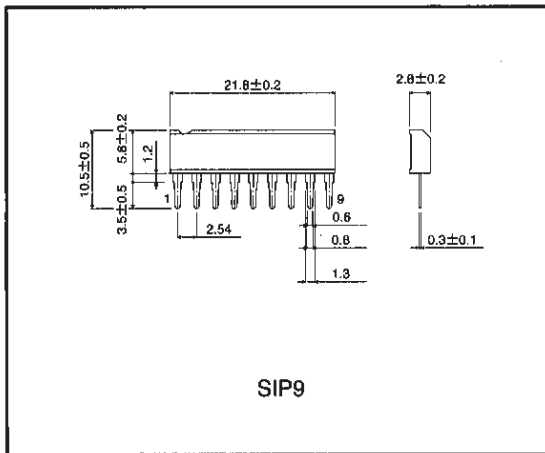

Fig. 2

● External dimensions (Unit: mm)



Power amplifiers

Low-frequency amplifiers