

**DESCRIPTION**

The LM119 series are precision high speed dual comparators fabricated on a single monolithic chip. They are designed to operate over a wide range of supply voltages down to a single 5V logic supply and ground. Further, they have higher gain and lower input currents than devices like the  $\mu$ A710. The uncommitted collector of the output stage makes the LM119 compatible with RTL, DTL and TTL as well as capable of driving lamps and relays at currents up to 25mA.

Although designed primarily for applications requiring operation from digital logic supplies, the LM119 series are fully specified for power supplies up to  $\pm 15V$ . It features faster response than the LM111 at the expense of higher power dissipation. However, the high speed, wide operating voltage range and low package count make the LM119 much more versatile than older devices like the  $\mu$ A711.

The LM119 is specified from  $-55^{\circ}C$  to  $+125^{\circ}C$ , the LM219 is specified from  $-25^{\circ}C$  to  $+85^{\circ}C$ , and the LM319 is specified from  $0^{\circ}C$  to  $+70^{\circ}C$ .

**FEATURES**

- Two independent comparators
- Operates from a single 5V supply
- Typically 80ns response time at  $\pm 15V$
- Minimum fan-out of 3 (each side)
- Maximum input current of  $1\mu A$  over temperature
- Inputs and outputs can be isolated from system ground
- High common mode slew rate
- Mil std 883 A, B, C available

**PIN CONFIGURATIONS**

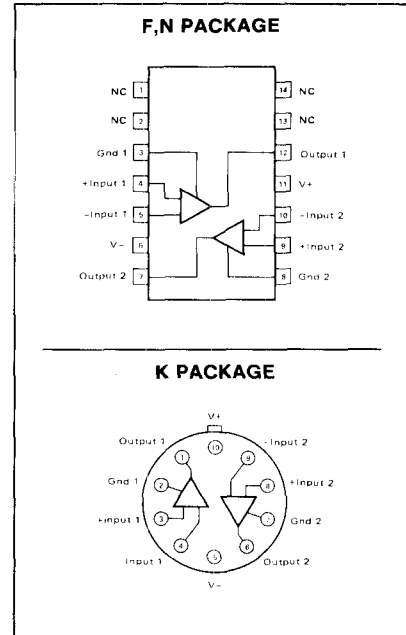

**EQUIVALENT SCHEMATIC**

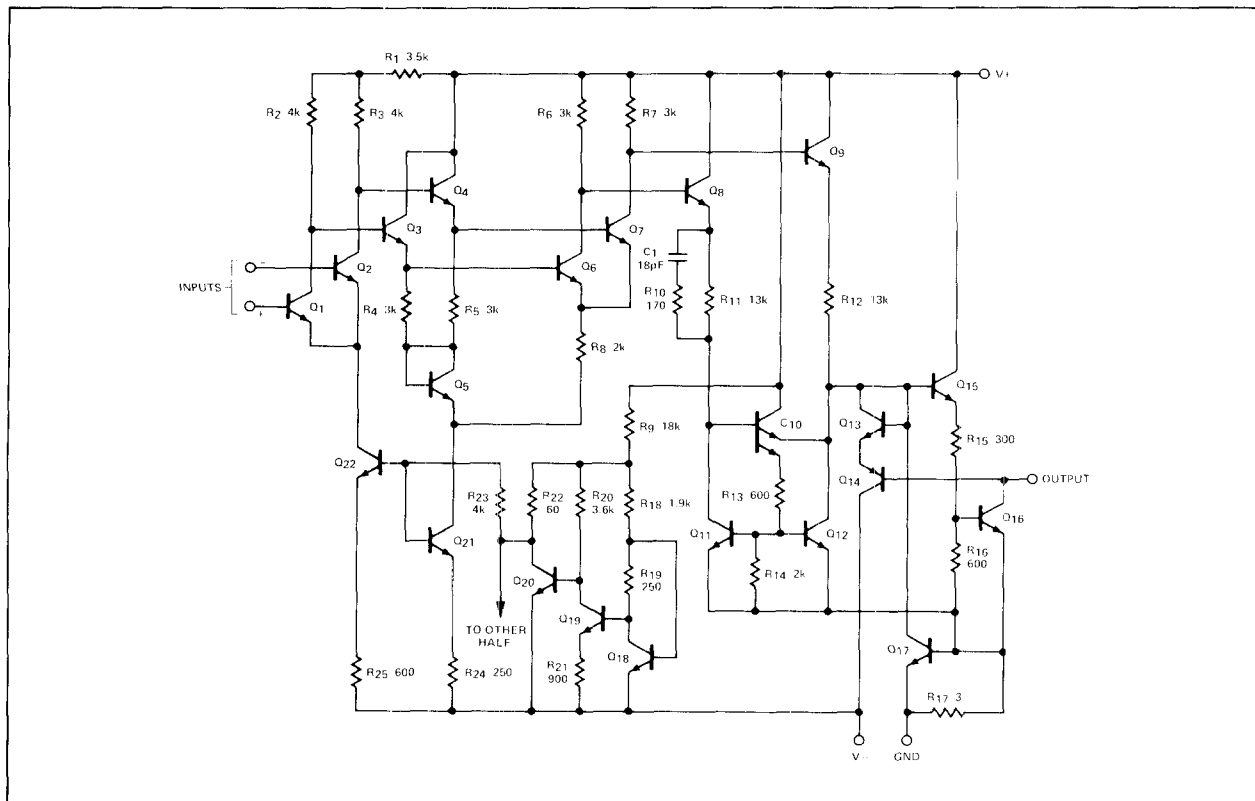

**ABSOLUTE MAXIMUM RATINGS**

PARAMETER	RATING	UNIT
Total supply voltage	36	V
Output to negative supply voltage	36	V
Ground to negative supply voltage	25	V
Ground to positive supply voltage	18	V
Differential input voltage	±5	V
Input voltage <sup>1</sup>	±15	V
Power dissipation <sup>2</sup>	500	mW
Output short circuit duration	10	s
Operating temperature range		
LM119	-55 to +125	°C
LM219	-25 to +85	°C
LM319	0 to +70	°C
Storage temperature range	-65 to +150	°C
Lead temperature (soldering, 10sec)	300	°C

NOTES

- For supply voltages less than ±15V, the absolute maximum rating is equal to the supply voltage.
- The absolute maximum junction temperature is 150°C. Device dissipation must be derated as follows:  
 N/K package—150°C/watt above 75°C  
 F package —110°C/watt above 95°C

**DC ELECTRICAL CHARACTERISTICS**  $V_S = \pm 15V$ , for  $\left. \begin{array}{l} \text{LM119, } -55^\circ\text{C} \leq T_A \leq 125^\circ\text{C} \\ \text{LM219, } -25^\circ\text{C} \leq T_A \leq 85^\circ\text{C} \\ \text{LM319, } 0^\circ\text{C} \leq T_A \leq 70^\circ\text{C} \end{array} \right\}$  unless otherwise specified.

PARAMETER	TEST CONDITIONS	LM119/219			LM319			UNIT
		Min	Typ	Max	Min	Typ	Max	
$V_{OS}$ Input offset voltage <sup>1,2</sup>	$R_S \leq 5K\Omega$ , $T_A = 25^\circ\text{C}$ Over temp.		0.7	4.0 7		2.0	8.0 10	mV mV
$I_{OS}$ Input offset current <sup>1,2</sup>	$T_A = 25^\circ\text{C}$ Over temp.		30	75 100		80	200 300	nA nA
$I_B$ Input bias current <sup>1</sup>	$T_A = 25^\circ\text{C}$ Over temp.		150	500 1000		250	1000 1200	nA nA
$A_V$ Voltage gain	$T_A = 25^\circ\text{C}$	10	40		8	40		V/mV
$V_{OL}$ Saturation voltage	$V_{IN} = 5mV$ , $I_{OUT} = 25mA$ , $T_A = 25^\circ\text{C}$ $V_{IN} = 10mV$ , $I_{OUT} = 25mA$ , $T_A = 25^\circ\text{C}$ $V^+ \geq 4.5V$ , $V^- = 0$ $V_{IN} = 6mV$ , $I_{OUT} = 3.2mA$ $T_A \geq 0^\circ\text{C}$ $T_A \leq 0^\circ\text{C}$ $V_{IN} = 10mV$ , $I_{OUT} = 3.2mA$		0.75  0.23	1.5  0.4 0.6		0.75  0.3	1.5  0.4	V V V V
$I_{OH}$ Output leakage current	$V^- = 0V$ , $V_{IN} = 5mV$ $V_{OUT} = 35V$ , $T_A = 25^\circ\text{C}$ Over temp. $V^- = 0V$ , $V_{IN} = 10mV$ $V_{OUT} = 35V$ , $T_A = 25^\circ\text{C}$		0.2 1	2 10		0.2	10	$\mu\text{A}$ $\mu\text{A}$ $\mu\text{A}$
$V_{IN}$ Input voltage range	$V_S = \pm 15V$ $V^+ = 5V$ , $V^- = 0V$	1	±13	3	1	±13	3	V V
$V_{ID}$ Differential input voltage				±5			±5	V
$I^+$ Positive supply current	$V^+ = 5V$ , $V^- = 0V$ , $T_A = 25^\circ\text{C}$		4.3			4.3		mA
$I^+$ Positive supply current	$V_S = \pm 15V$ , $T_A = 25^\circ\text{C}$		8.0	11.5		8.0	12.5	mA
$I^-$ Negative supply current	$V_S = \pm 15V$ , $T_A = 25^\circ\text{C}$		3.0	4.5		3.0	5.0	mA

NOTES

- $V_{OS}$ ,  $I_{OS}$  and  $I_B$  specifications apply for a supply voltage range of  $V_S = \pm 15V$  down to a single 5V supply.
- The offset voltages and offset currents given are the maximum values required to drive the output to within 1 volt of either supply with a 1mA load. Thus these parameters define an error band and take into account the worst case effects of voltage gain and input impedance.

AC ELECTRICAL CHARACTERISTICS

PARAMETER	TEST CONDITIONS	LIMITS			UNIT
		Min	Typ	Max	
Response time*	$V_S = \pm 15V, T_A = 25^\circ C$ $R_L = 500\Omega$ (see test figure)		80		ns

\*NOTE

The response time specified is for a 100mV step with 5mV overdrive.

TEST CIRCUIT

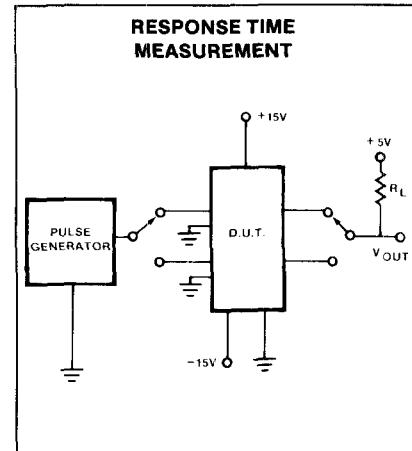

TYPICAL PERFORMANCE CHARACTERISTICS

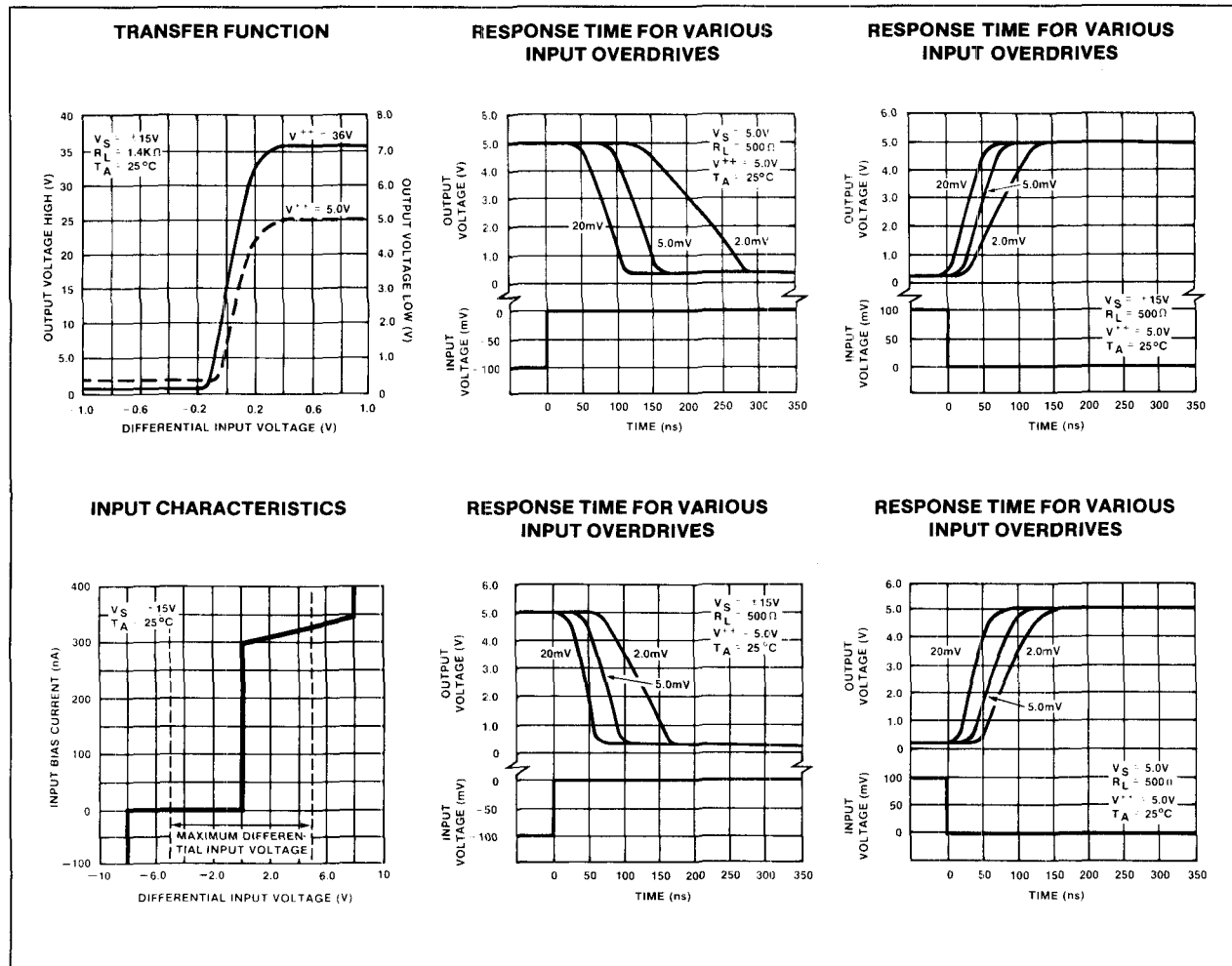

TYPICAL PERFORMANCE CHARACTERISTICS (Cont'd)

OUTPUT SATURATION VOLTAGE

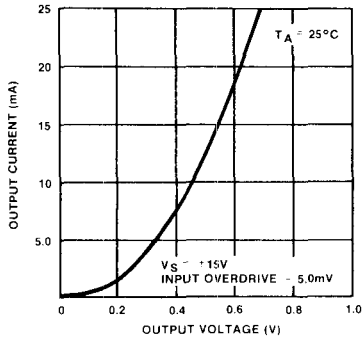

SUPPLY CURRENT

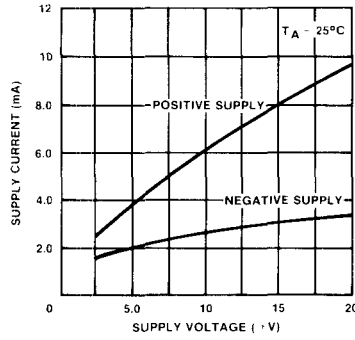

OUTPUT LIMITING CHARACTERISTICS

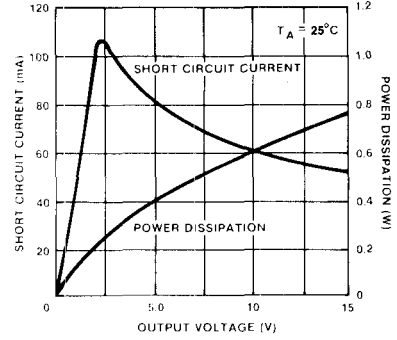

INPUT CURRENTS (LM119/219)

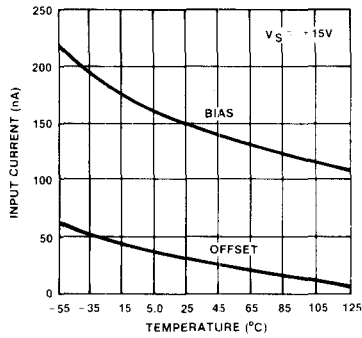

COMMON MODE LIMITS (LM119/219)

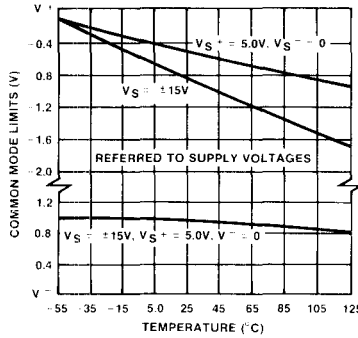

SUPPLY CURRENT (LM119/219)

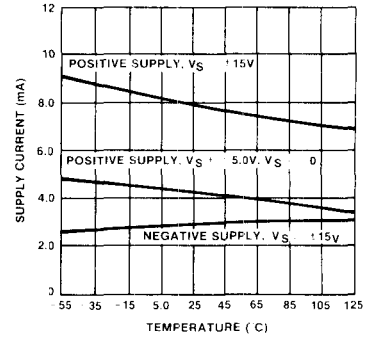

INPUT CURRENTS (LM319)

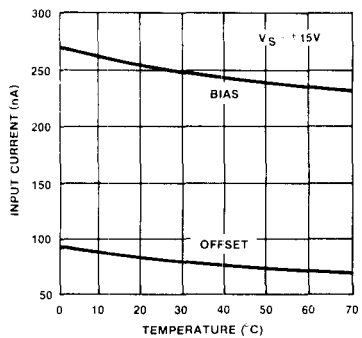

SUPPLY CURRENTS (LM319)

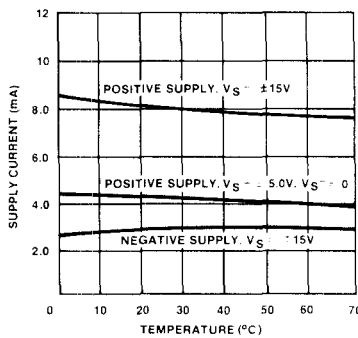

COMMON MODE LIMITS (LM319)

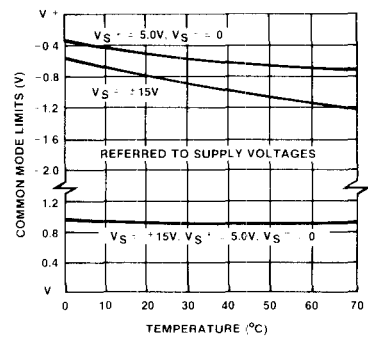

5

TYPICAL APPLICATIONS

RELAY DRIVER

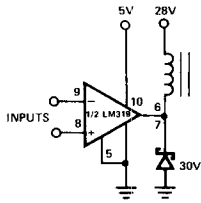

WINDOW DETECTOR

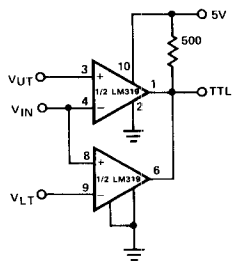

$V_{OUT} = 5V$  for  $V_{LT} < V_{IN} < V_{UT}$   
 $V_{OUT} = 0$  for  $V_{IN} < V_{LT}$  or  $V_{IN} > V_{UT}$

WIDE RANGE VARIABLE OSCILLATOR

