

DATA SHEET



BIPOLAR ANALOG INTEGRATED CIRCUIT

μ PC1228

LOW NOISE DUAL PREAMPLIFIER

DESCRIPTION

The μ PC1228, a silicon monolithic integrated circuit, is a low noise dual preamplifier designed for car stereo applications. The device consists of two separate amplification channels, and its major features are low noise, low distortion, high gain, large dynamic range and wide supply voltage range.

FEATURES

- High open loop gain : $A_{VO} = 100$ dB TYP.
- Low noise : $V_{nin} = 1.1$ μ V TYP.
- Low distortion : THD = 0.05 % TYP.
- Large dynamic range : $V_{OM} = 2.0$ V TYP.
- Wide supply voltage range : $V_{CC} = 6$ to 16 V
- High output current : $I_{ODC} = 1$ mA MAX.
- Low impedance load driving capability : $R_L = 1$ k Ω MIN.
- Small feedback capacitance capability

ORDERING INFORMATION

PART NUMBER	PACKAGE	QUALITY GRADE
μ PC1228HA	8 PIN PLASTIC SLIM SIP	Standard

Please refer to "Quality grade on NEC Semiconductor Devices" (Document number IEI-1209) published by NEC Corporation to know the specification of quality grade on the devices and its recommended applications.

CONNECTION DIAGRAM

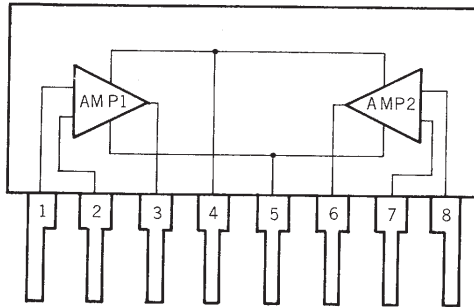

Pin No.	Electrical connection
1	Input 1
2	Negative feed back 1
3	Output 1
4	Power supply: +V _{CC}
5	Ground
6	Output 2
7	Negative feed back 2
8	Input 2

ABSOLUTE MAXIMUM RATINGS (T_a = 25 °C)

Supply Voltage	V _{CC}	18	V
Package Dissipation	P _D	270*	mW
Operating Temperature	T _{opt}	-30 to +75	°C
Storage Temperature	T _{stg}	-40 to +125	°C

* T_a = 75 °C

RECOMMENDED OPERATING CONDITIONS (T_a = 25 °C)

Operating Supply Voltage	V _{CC}	13.2	V
Supply Voltage Range	V _{CC}	6 to 16	V
Operating Ambient Temperature	T _a	-30 to +75	°C
Load impedance	R _L	10	kΩ

ELECTRICAL CHARACTERISTICS (T_a = 25 °C, V_{CC} = 10 V, f = 1 kHz, R_L = 10 kΩ)

CHARACTERISTIC	SYMBOL	MIN.	TYP.	MAX.	UNIT	TEST CIRCUIT	TEST CONDITIONS
Quiescent Current	I _{CC}	2.5	3.3	4.8	mA	(1)	V _{in} = 0
Open Loop Voltage Gain	A _{vo}	90	100		dB	(1)	V _O = 0.3 V, f = 100 Hz
Voltage Gain	A _v		40		dB	(2)	V _O = 0.3 V, NAB
Maximum Output Voltage	V _{OM}	1.0	2.0		V	(2)	THD = 1 %, NAB
Total Harmonic Distortion	THD		0.05	0.3	%	(2)	V _O = 0.3 V, NAB
Input Impedance	r _i	50	100		kΩ	(2)	
Equivalent Input Noise Voltage	V _{nin}		1.1	1.7	μV	(3)	R _G = 2.2 kΩ, NAB
Cross Talk	CT	-50	-65		dB	(4)	V _O = 1 V, (The other channel V _{in} = 0, R _G = 2.2 kΩ)
Channel Balance	Ch. B	-0.3	0	+0.3	dB	(4)	V _O = 0.3 V

TEST CIRCUITS

(1) I_{CC} , A_{V0} test circuit

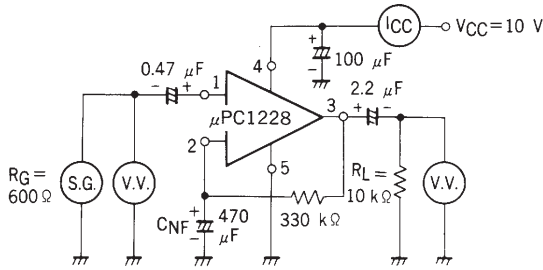

(2) A_v , V_{OM} , THD, Z_{in} test circuit (for Ch. 1)

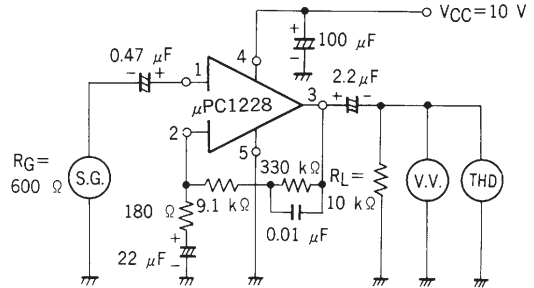

(3) V_{nin} test circuit (for Ch. 1)

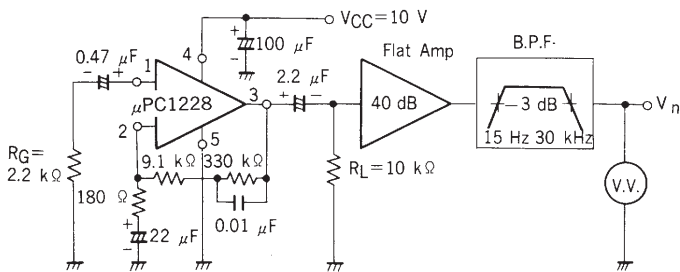

NOTE: V_{nin} is calculated by V_n and amp. gain ($A_v + 40$ dB).

(4) Cross talk, Channel balance test circuit

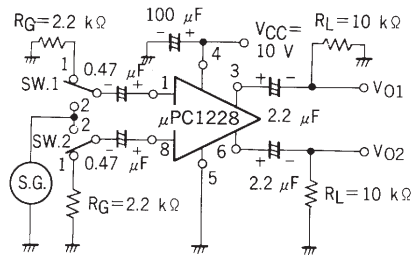

NOTE 1: External components of the IC are the same as the test circuit (2).

2: Cross talk procedure

Switch position SW.1 \rightarrow 2, SW.2 \rightarrow 1, $20 \log V_{O2}/V_{O1}$

Switch position SW.1 \rightarrow 1, SW.2 \rightarrow 2, $20 \log V_{O1}/V_{O2}$

3: Channel balance

Switch position SW.1 \rightarrow 2, SW.2 \rightarrow 2, $20 \log V_{O1}/V_{O2}$

EQUIVALENT CIRCUIT

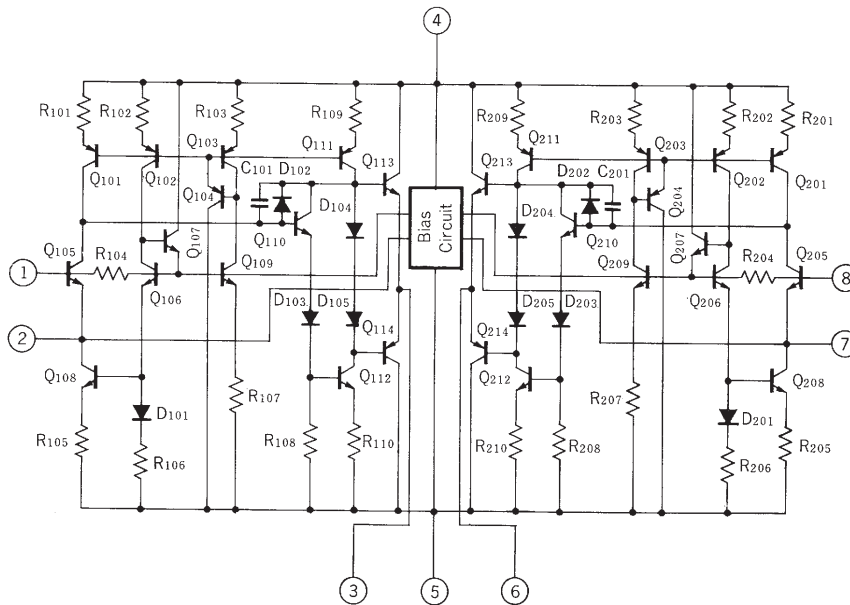

TYPICAL CHARACTERISTICS ($T_a = 25^\circ\text{C}$)

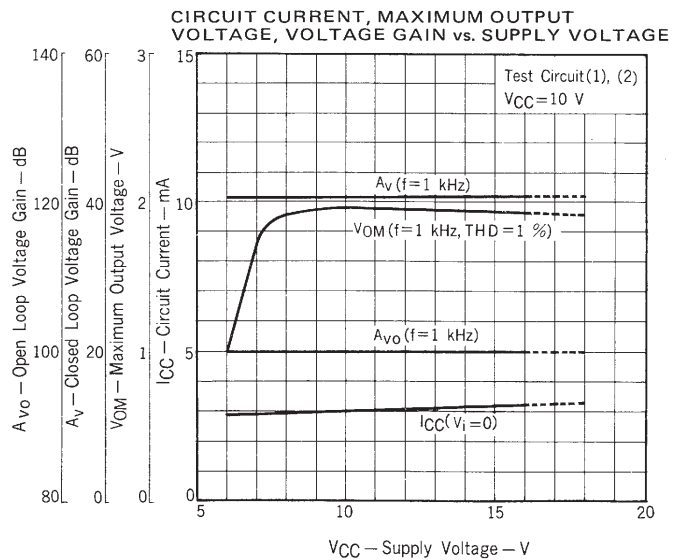
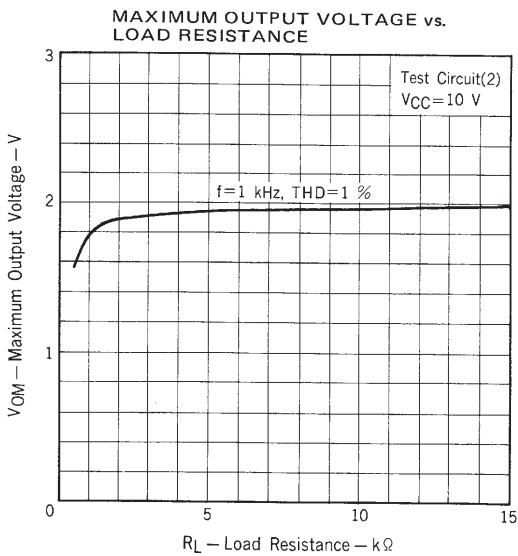
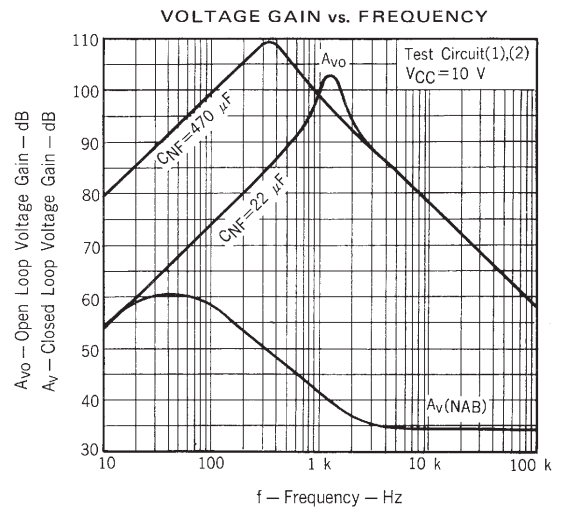
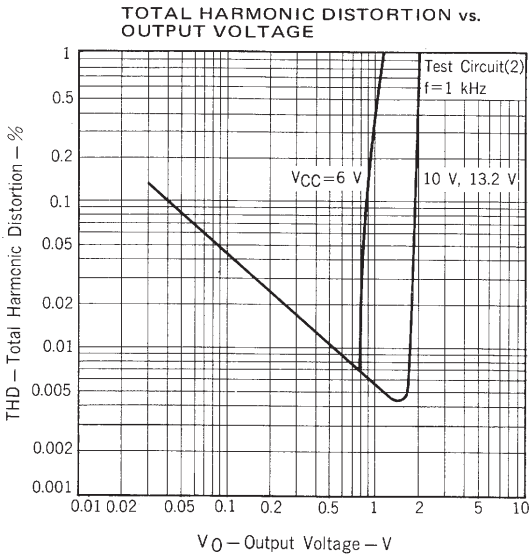
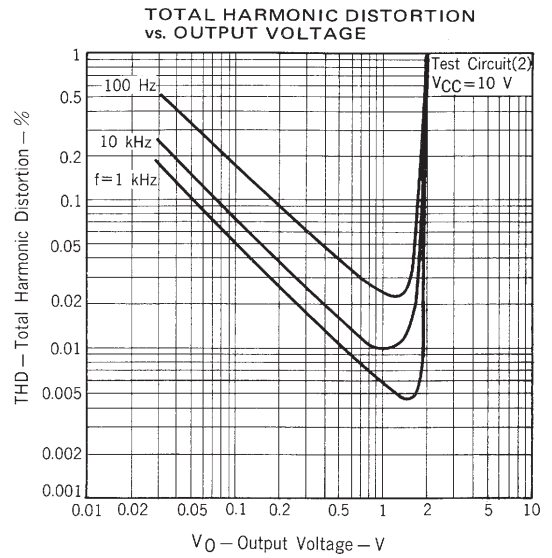
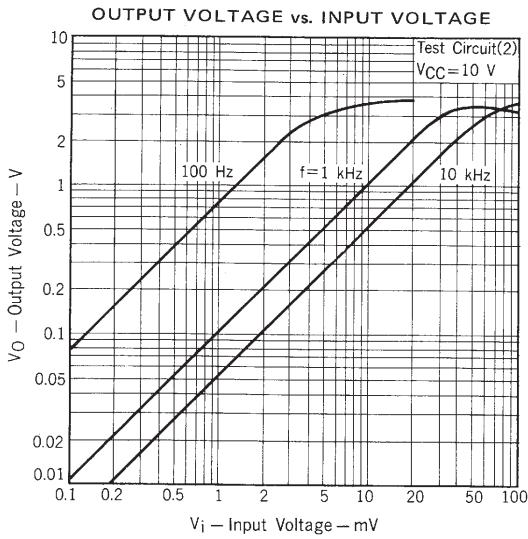

MAXIMUM OUTPUT VOLTAGE vs. FEEDBACK RESISTANCE

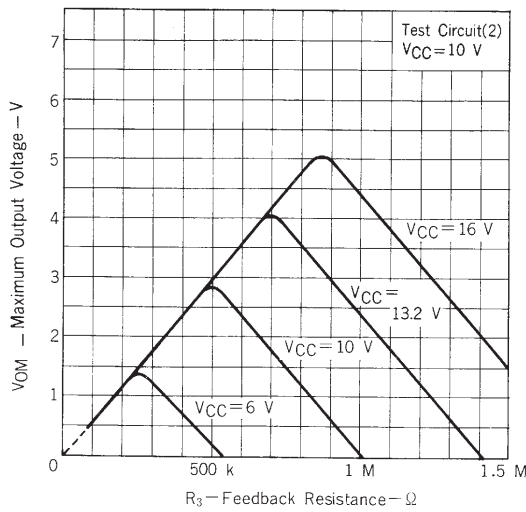

MAXIMUM OUTPUT VOLTAGE vs. SUPPLY VOLTAGE

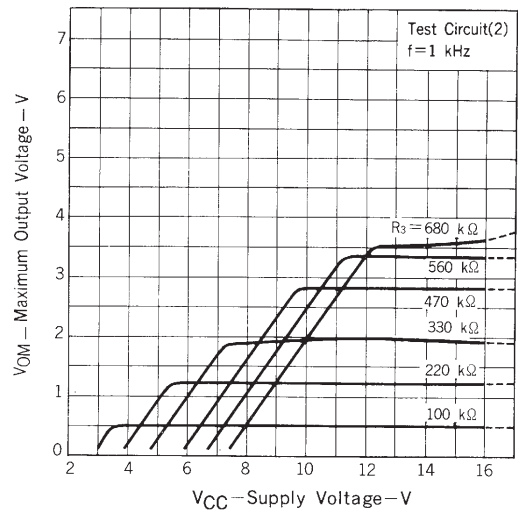

VOLTAGE GAIN vs. FREQUENCY

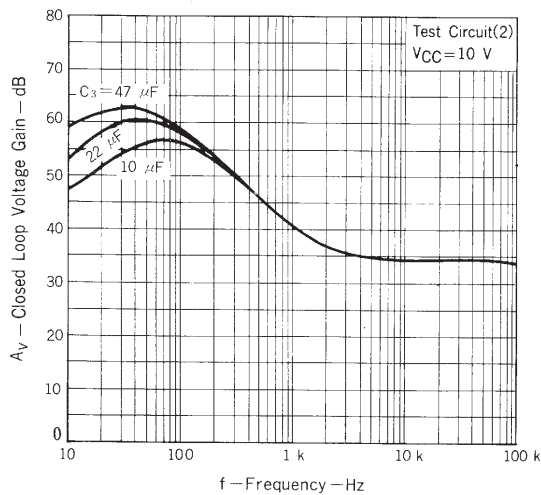

VOLTAGE GAIN vs. FREQUENCY

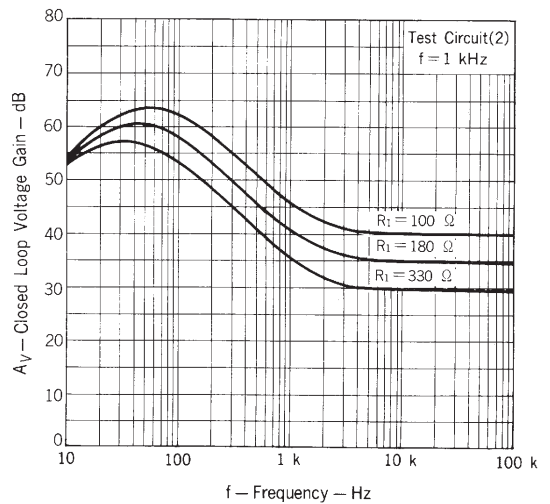

QUIESCENT CURRENT, MAXIMUM OUTPUT VOLTAGE, VOLTAGE GAIN vs. AMBIENT TEMPERATURE

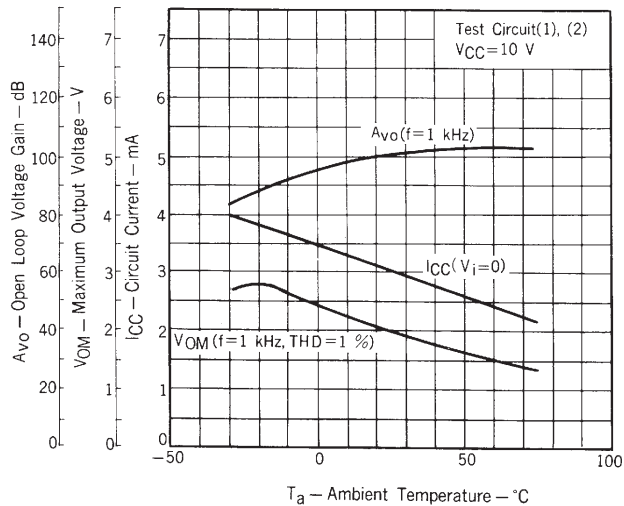

MAXIMUM OUTPUT VOLTAGE vs. AMBIENT TEMPERATURE

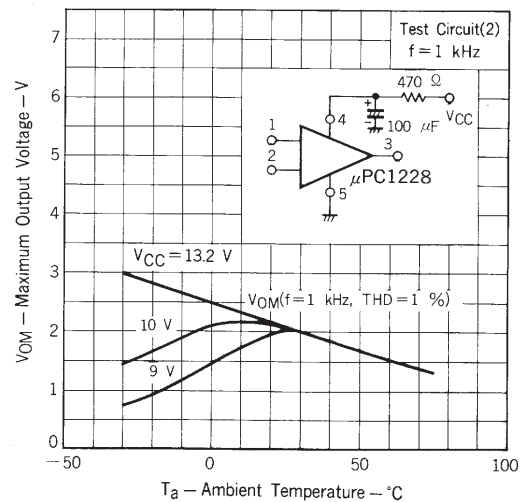

APPLICATION 1 (NAB EQ, $V_{CC} = 8$ to 17 V, $V_{OM} = 2$ V)

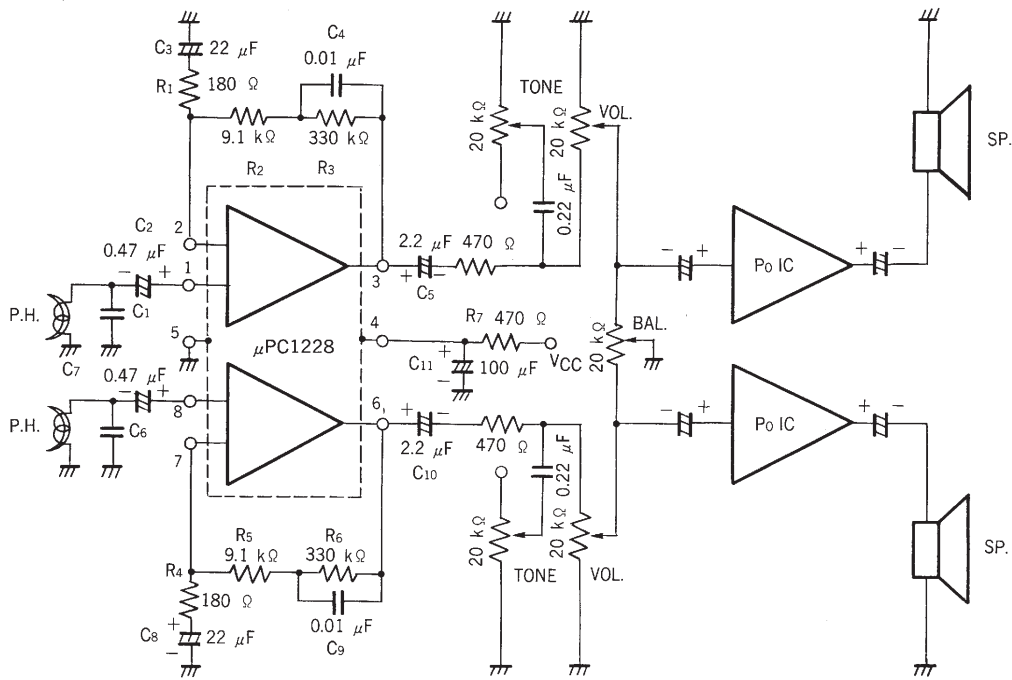

APPLICATION 2 (NAB EQ, $V_{CC} = 6$ to 17 V, $V_{OM} = 1.2$ V)

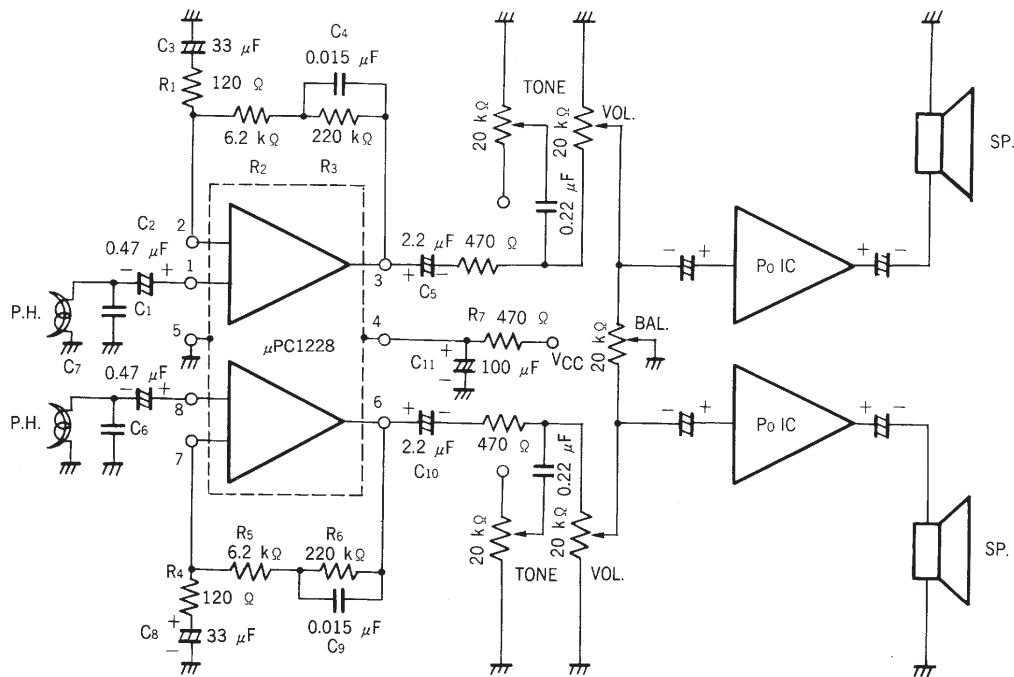

* When supply voltage of pin ④ is down to 6 V, please use TYPICAL APPLICATION 2.

APPLICATION 3 (NAB EQ, $V_{CC} = 8$ to 18 V, $V_{OM} = 2$ V)

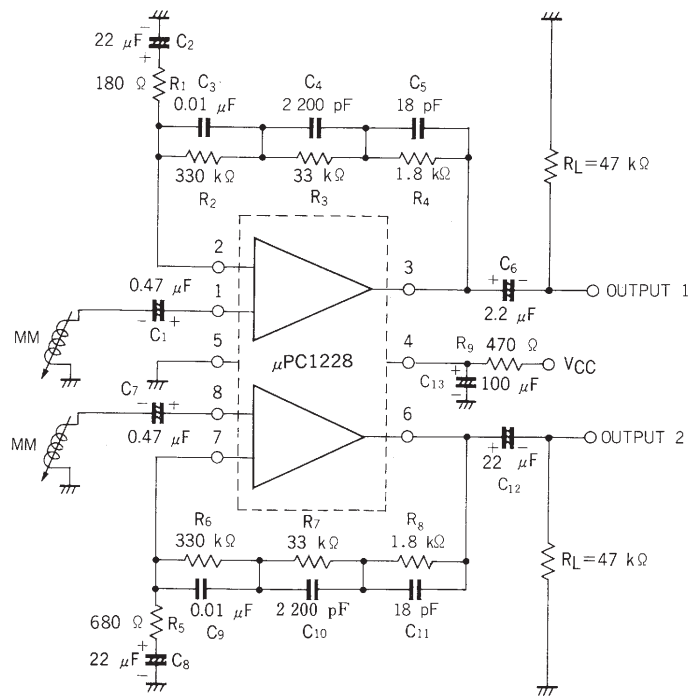

TYPICAL PRINTED CIRCUIT BOARD PATTERN
Copper foil side

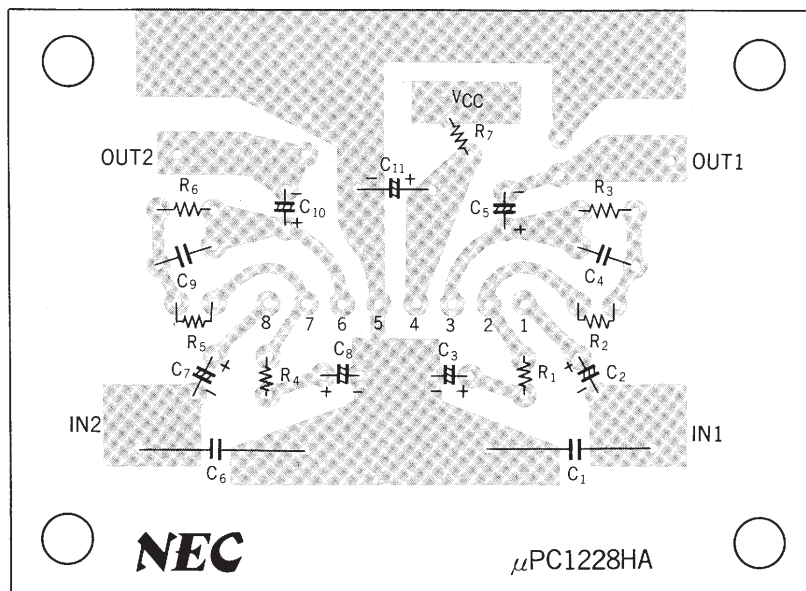

8 PIN PLASTIC SLIM SIP

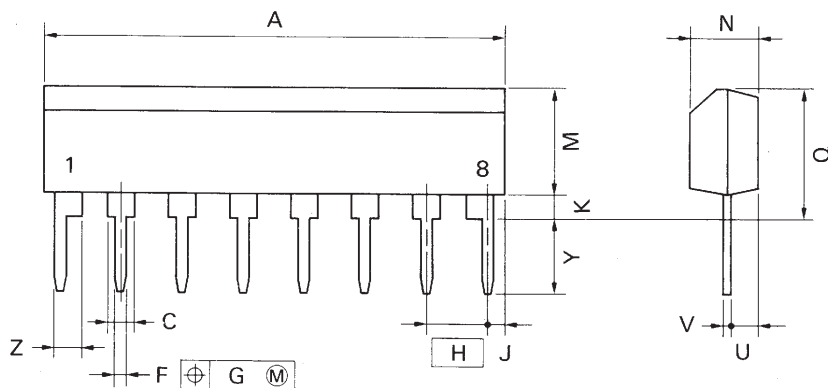

P8HA-254B

NOTE

Each lead centerline is located within 0.25 mm (0.01 inch) of its true position (T.P.) at maximum material condition.

ITEM	MILLIMETERS	INCHES
A	20.32 MAX.	0.8 MAX.
C	1.1 MIN.	0.043 MIN.
F	0.5 ^{+0.1}	0.02 ^{+0.004}
G	0.25	0.01
H	2.54	0.1
J	1.27 MAX.	0.05 MAX.
K	0.51 MIN.	0.02 MIN.
M	5.08 MAX.	0.2 MAX.
N	2.8 ^{+0.2}	0.11 ^{+0.008}
Q	5.75 MAX.	0.227 MAX.
U	1.5 MAX.	0.059 MAX.
V	0.25 ^{+0.10}	0.01 ^{+0.003}
Y	3.2 ^{+0.5}	0.126 ^{+0.02}
Z	1.1 MIN.	0.043 MIN.

[MEMO]

No part of this document may be copied or reproduced in any form or by any means without the prior written consent of NEC Corporation. NEC Corporation assumes no responsibility for any errors which may appear in this document.

NEC Corporation does not assume any liability for infringement of patents, copyrights or other intellectual property rights of third parties by or arising from use of a device described herein or any other liability arising from use of such device. No license, either express, implied or otherwise, is granted under any patents, copyrights or other intellectual property rights of NEC Corporation or others.

The devices listed in this document are not suitable for use in the field where very high reliability is required including, but not limited to, aerospace equipment, submarine cables, nuclear reactor control systems and life support systems. If customers intend to use NEC devices for above applications or othose intend to use "Standard" quality grade NEC devices for the application not intended by NEC, please contact our sales people in advance.

Application examples recommended by NEC Corporation

Standard: Data processing and office equipment, Communication equipment (terminal, mobile), Test and Measurement equipment, Audio and Video equipment, Other consumer products, Industrial robots, etc.

Special: Automotive and Transportation equipment, Communication equipment (trunk line), Train and Traffic control devices, Burning control systems, antidisaster systems, anticrime systems etc.